



AC/DC INPUT, PROFESSIONAL
BALANCE CHARGER, DISCHARGER
multi charger X4AC PLUS



Instruction Manual

TABLE OF CONTENTS

Introduction.....	01
Charger Layout.....	03
Special Features.....	04
Warnings and Safety Information.....	06
Default User Preferences Setup.....	09
Connecting the Battery.....	11
Program Flow Chart.....	12
Program Display Information.....	13
Charging Lithium Chemistry (LiPo/LiIo/LiFe) Type Batteries.....	13
Discharging Lithium Chemistry (LiPo/LiIo/LiFe) Type Batteries.....	16
Charging/Discharging and Cycling NiCd or NiMH Batteries.....	17
Charging/Discharging Lead-Acid (Pb) Batteries.....	18
Battery Data Preset Storage and Load Feature.....	20
Warning and Error Messages.....	21
Recommended Accessories.....	22
Conformity and Regulatory Information.....	22
Warranty and Servicing.....	23

INTRODUCTION

Congratulations on your purchase of the Hitec X4 AC Plus Multi-Charger. You are now the owner of a compact multi chemistry battery charger with battery management and integral Lithium battery balancing features. The X4 AC Plus features four totally independent and identical 50 watt charging circuits for a total power of 200 watts. As a result, it can simultaneously charge or discharge up to 4 separate battery packs.

The X4 AX Plus can accept a variety of power inputs. The charger features a built in 22 Amp power supply powered by your standard 100-120 V AC household current or you can attach it to a 12 Volt car battery or a 11 – 15 V (20 amp minimum) DC power supply.

The Hitec X4 AC Plus is simple to use, but the operation of a sophisticated automatic charger such as the X4 AC Plus does require some knowledge and education by the user. This instruction manual is designed to ensure that you can quickly become familiar with the charger's functions and capabilities. It is important that you read this instruction manual in its entirety before attempting to use your new X4 AC Plus chargers.

Package Contents

- | | |
|--------------------------------------|----------------------------------------|
| 1. Hitec X4 Plus | 7. Receiver Battery Charging Connector |
| 2. AC Input Cable | 8. 2 x Bare Wire Connectors |
| 3. DC Input Cable | 9. 1 x TP/FP Type LiPo Balancer Board |
| 4. Battery Clamps | 10. 1 x HP/PQ Type LiPo Balancer Board |
| 5. Alligator Clip Charging Connector | 11. 1 x XH Type LiPo Balancer Board |
| 6. Tamiya Charging Connector | |



INTRODUCTION

The Hitec X4 AC Plus allows you to charge up to four different batteries simultaneously. The charger will automatically charge all 4 batteries at a time to their maximum capacity. Additionally the batteries being charged do not need to have the same configuration or the same chemistry. Therefore you can connect any one of a NiMH/NiCD/LiPo/LiFe battery into any of the charging ports. This eliminates the time consuming efforts of charging all your batteries separately.

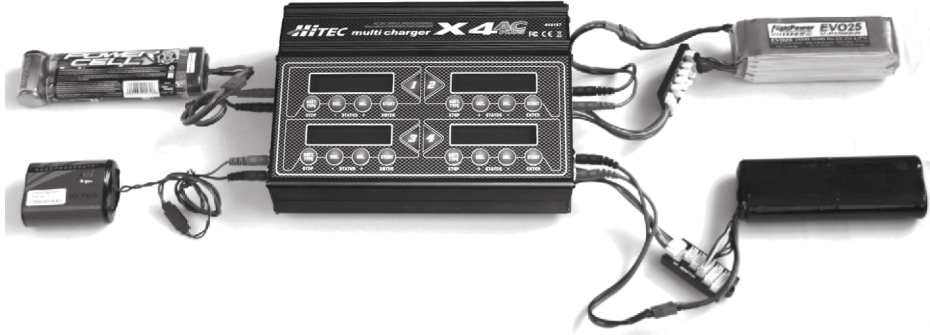

Specifications

Power Source	100-120V AC, 12V DC Car Battery or 11-15V DC Power Supply
Operating Voltage Range	DC 11 - 15 Volt
Charge Power	50 Watts, current is regulated accordingly e.g. 11.1V battery, charge current approx. 4.5 A e.g. 22.2 V battery, charge current approx. 2.2 A
Discharger Power	5 Watts, current is regulated accordingly
Cell Count	1-15 NiCd/NiMH cells 1-6 LiPo/Lilon/LiFe cells 1-10 Lead-Acid cells (2V - 20V)
Current Drain for Balancing Lithium	300mA
Charge Termination	
NiCd/NiMH	Automatic, negative delta-peak method
Lead-Acid and Lithium	Automatic, voltage-dependent, CC-CV process
Dimensions	8.9" x 6.7" x 2.6"
Net Weight	3.4 lbs.

CHARGER LAYOUT

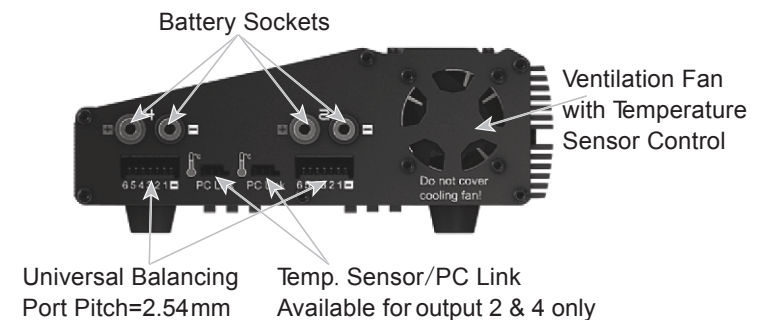
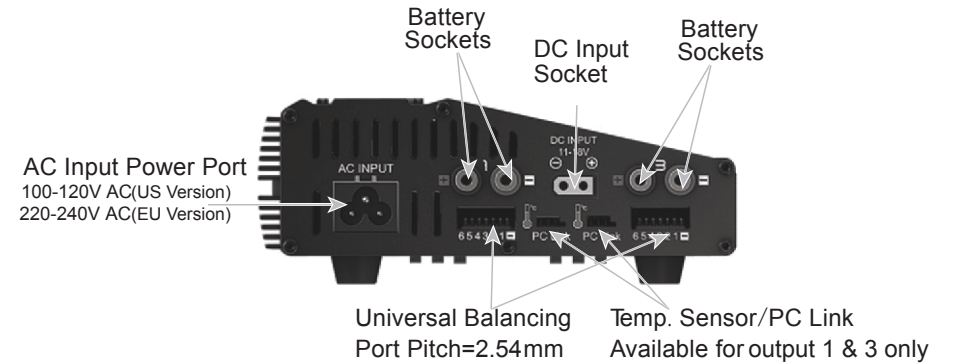
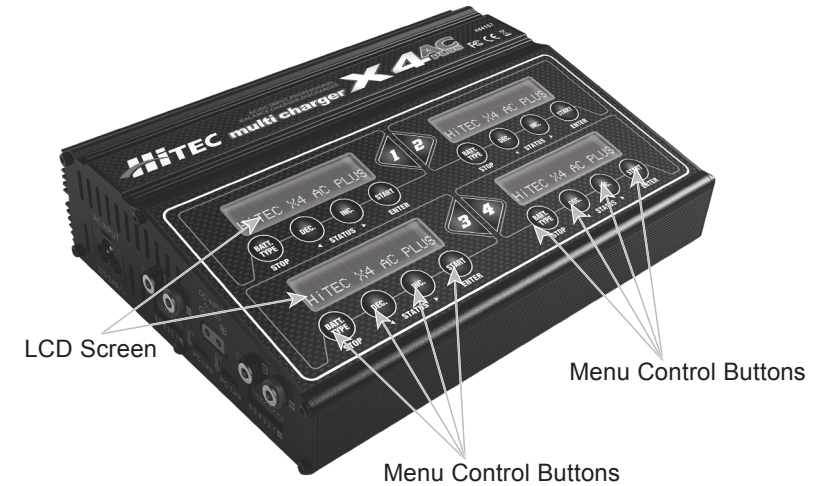

Optimized Operating Software

The software in X4 AC Plus automatically controls the current rate during the charging or discharging process. This feature can prevent the user from overcharging their batteries which could lead to damage or injury. If the charger detects a malfunction, the circuit automatically disconnects and an alarm will sound. The operating functions of the X4 AC Plus are controlled through a two-way communication link in order to maintain maximum safety with minimal errors. All of these functions and settings are easily configured by the user.

Internal Independent Lithium Battery Balancers

Each channel of the X4 AC Plus employs an individual-cell voltage balancer eliminating the need for an external balancer for balance charging.

Balancing Individual Cells during Battery Discharging

During the process of discharging, the X4 AC Plus can monitor and balance each cell of the lithium battery individually. If the voltage of any single cell is abnormal, an error message will display and the discharge process will automatically end.

Charges Most Popular Lithium Batteries

The X4 AC Plus is compatible with the three most common Lithium chemistry batteries, Li-Ion, LiPo and LiFe.

Multiple Lithium Battery Charge Modes

The X4 AC Plus's programming allows for Fast Charge, Balance Charge or Storage Charge Modes for LiPo, Li-Ion, and LiFe batteries.

- **Fast Charge Mode:** Reduces charging time, but does not balance the cells, this mode only charges the battery to approximately 90% capacity.
- **Balance Charge Mode:** Monitors individual cell voltage, keeping the cells within an acceptable voltage range and charges the pack to peak capacity.
- **Storage Charge Mode:** Used for long-term battery storage. Adjusts the voltage level so the battery will not be damaged during long term storage.

Delta Peak Technology for Maximum Safety

The automatic charge termination program utilizes Delta-Peak voltage detection. When the battery's voltage exceeds the threshold, the charge process is terminated automatically.

Automatic Charging Current Limit

The maximum charge rate can be manually set when charging NiCd or NiMH batteries. The X4 AC Plus will auto-detect when the batteries are fully charged and shut off, even with low impedance NiMH packs.

Capacity and Processing Time Limit

The charging capacity is calculated as the charging current multiplied by time. If the charging capacity exceeds the maximum limit set by the user, the process will terminate automatically. Additionally the user can set the maximum amount of charging time. If the charging time exceeds this limit, the process will terminate automatically.

Temperature Threshold*

The battery's internal chemical reaction causes the temperature of the battery to rise during the charging process. If the temperature exceeds the limit, the charging process will automatically terminate.

* This function is available by connecting an optional temperature probe, which is not included in our package.

10 User Customizable Presets

The X4 AC Plus features 10 individually customizable presets so the user can store the charge and discharge parameters for any particular battery type. These presets can be recalled for the desired battery type without the need for any additional programming.

Cyclic Charging / Discharging

Batteries can be set to automatically Charge/Discharge or Discharge/Charge up to a maximum of 5 cycles.

PC Based Analysis Using USB Communication*

The Hitec X4 AC Plus offers a PC-based program which can analyze the characteristics of the battery via a USB port. It shows a graph of voltage, current and capacity curves. It also displays the individual voltage of each cell in the lithium battery pack.

* Using optional PC-LINK USB Adapter (sold separately) and software that can be downloaded from www.hitecrd.com

WARNINGS AND SAFETY INFORMATION

WARNING

FAILURE TO FOLLOW THESE IMPORTANT SAFETY NOTES OR THE INSTRUCTION MANUAL CAN RESULT IN SEVERE INJURY, PROPERTY DAMAGE OR LOSS OF LIFE.

- ❗ Please read this entire instruction manual completely and attentively before using this product, as it covers a wide range of information on operation and safety.
- ❗ Never leave the charger unattended when it is connected to its power supply. If any malfunction is found, TERMINATE THE PROCESS AT ONCE and refer to the instruction manual.
- ❗ Keep the charger away from dust, moisture, water, excessive heat, direct sunlight and vibration.
- ❗ The maximum allowable input voltage is 120 VAC when using the supplied AC power cord or 15V DC when using an external DC power source.
- ❗ The charger and the battery should be put on a heat-resistant, non-flammable and non-conductive surface. Never place them on a car seat, carpet or other flammable surface. Keep all flammable volatile materials away from the operating area.
- ❗ Make sure you know the specifications of the battery you are charging or discharging to ensure it meets the requirements of this charger. If the program is set up incorrectly, the battery and charger may be damaged. Fire or explosion can occur due to overcharging.
- ❗ To avoid short circuiting between the charge lead, always connect the charge cable to the charger first, then connect the battery. Reverse the sequence when disconnecting.
- ❗ **Never Attempt to Charge or Discharge the Following Types of Batteries**
 - A battery pack which consists of different types of cells (including different manufacturers)
 - A battery that is already fully charged or just slightly discharged
 - Non-rechargeable batteries (they pose an explosion hazard)
 - Batteries that require a different charge technique from NiCd, NiMH, LiPo or gel cell (Pb, lead-acid battery)
 - A faulty or damaged battery
 - A battery fitted with an integral charge circuit or a protection circuit
 - Batteries installed in a device or which are electrically linked to other components
 - Batteries that are not expressly stated by the manufacturer to be suitable for the currents the charger delivers during the charge process

WARNINGS AND SAFETY INFORMATION

❗ Before you Start Charging or Discharging your Batteries Consider the Following

- Did you select the appropriate program suitable for the type of battery you are charging?
- Did you set up adequate current for charging or discharging?
- Have you checked the battery voltage? Lithium battery packs can be wired in parallel and in series, i.e. a 2-cell pack can be 3.7V (in parallel) or 7.4V (in series).
- Have you checked that all connections are firm and secure? Make sure there are no intermittent contacts at any point in the circuit.

Standard Battery Parameters

	LiPo	LiIon	LiFe	NiCd	NiMH	Pb
Nominal Voltage	3.7V/cell	3.6V/cell	3.3V/cell	1.2V/cell	1.2V/cell	2.0V/cell
Max Charge Voltage	4.2V/cell	4.1V/cell	3.6V/cell	1.5V/cell	1.5V/cell	2.46V/cell
Storage Voltage	3.8V/cell	3.7V/cell	3.3V/cell	n/a	n/a	n/a
Allowable Fast Charge	≦ 1C	≦ 1C	≦ 4C	1C-2C	1C-2C	≦ 0.4C
Min. Discharge Voltage	≧ 3.0V/cell	≧ 2.5V/cell	≧ 2.0V/cell	≧ 0.85V/cell	≧ 1.0V/cell	≧ 1.75V/cell

❗ Charging

During the charge process, a specific quantity of electrical energy is fed into the battery. The charge quantity is calculated by multiplying charge current by charge time. The maximum permissible charge current varies depending on the battery type or its performance, and can be found in the information provided by the battery manufacturer. Only batteries that are expressly stated to be capable of quick charge should be charged at rates higher than the standard charge current.

Connect the battery to the terminal of the charger. Red is positive and black is negative. In the event there is any significant resistance in the battery cable and/or connector, the charger will not be able to properly detect the resistance of the battery pack resulting in an error. It is essential in order for the charger to operate properly that the battery charge leads should be of adequate quality for the size of the battery.

Always refer to the manual by the battery manufacturer pertaining to charging methods. Operate according to their recommended charging current and charging time. Lithium batteries, in particular, should be charged strictly according to the manufacturer's instruction.

Pay close attention to the connection of lithium batteries.

Do not attempt to disassemble the battery pack.

Please take note that lithium battery packs can be wired in parallel and in series. In the parallel connection, the battery's capacity is calculated by multiplying the single battery's capacity by the number of cells, bearing in mind that total voltage stays the same. If the voltage is imbalanced, it may cause a fire or explosion. Lithium batteries are always recommended to be charge in series.

⚠ Discharging

The main purpose of discharging a battery is to clean the residual capacity of the battery or to reduce the battery's voltage to a defined level. It is critical that the same attention be paid to the discharging process as to the charging process. The final discharge voltage should be set correctly to avoid deep discharging. Lithium batteries cannot be discharged to voltage lower than the minimum voltage for the cell type. Doing so will result in a rapid loss of capacity and/or total failure. Generally, lithium batteries don't need to be discharged and it is not recommended. If you choose to discharge your lithium batteries make sure to pay attention to the minimum voltage setting.

Some rechargeable batteries have a memory effect. If they are partly used and recharged before the complete charge/discharge cycle is accomplished, they remember this and will only use that part of their capacity next time. It is generally known that NiCd and NiMH batteries suffer from this memory effect.

NOTICE

THIS CHARGER WAS DESIGNED AND APPROVED EXCLUSIVELY FOR USE WITH THE TYPES OF BATTERIES STATED IN THIS INSTRUCTION MANUAL. HITEC RCD USA ACCEPTS NO LIABILITY OF ANY KIND IF THE CHARGER IS USED FOR ANY PURPOSE OTHER THAN THAT STATED. SINCE WE ARE UNABLE TO ASSURE THAT THE USER WILL PROPERLY FOLLOW THE SUPPLIED INSTRUCTIONS AND HAVE NO CONTROL OVER ONE'S PROPER USE OR MAINTENANCE OF THE DEVICE, WE ARE OBLIGATED TO DENY ANY AND ALL CLAIMS OF LIABILITY FOR LOSS, DAMAGE OR INJURY WHICH ARE INCURRED DUE TO IMPROPER USE AND OPERATION OF THIS PRODUCT. UNLESS OTHERWISE PRESCRIBED BY LAW, THE LIMIT OF OUR LIABILITY SHALL NOT EXCEED THE INVOICE VALUE OF THE CHARGER.

POWERING THE CHARGER

The Hitec X4 AC Plus comes with a built in switching power supply allowing you to connect it directly to a 120 VAC wall socket using the supplied AC power cord. The charger can also be powered by a 12VDC car battery using the included large terminal clips with matching 4mm female bullet connectors or it can be connected directly to a DC power supply. When connecting to a battery or power supply it is critically important that you use either a fully charged 12 volt car battery or a high quality DC power supply that has a voltage range between 12V to 15V DC and a minimum current rating of 20A. Failure to use proper input power can result in unreliable performance and may damage the charger.



4mm bullet connectors plug directly into most power supplies.



Using terminal clip attaching to car battery.

When powered on for the first time the X4 AC Plus will load a set of default parameters most commonly used by most users. The screen displays the information in the following sequence. The user can customize the parameters on each screen to suit their own preferences.

To change the parameter values in the program, press the **Start/Enter** key to choose the parameter you want to change. Once the parameter is blinking you can change the value with the **INC** (up/forward) or **DEC** (down/back) keys. The value will be stored by pressing the **Start/Enter** key once and the blinking stops.

⚠ WARNING
DO NOT CONNECT A BATTERY TO THE CHARGER BEFORE SETTING UP THE DEFAULT USER PREFERENCES

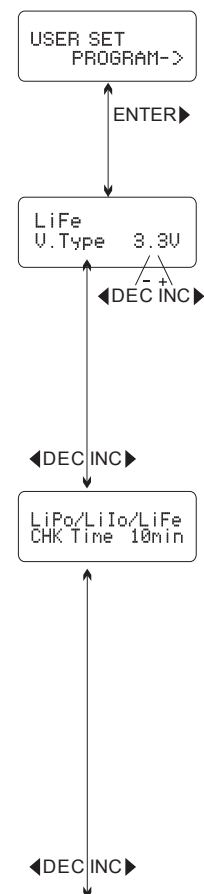

Main User Setup Screen

The first screen displayed is the Lithium battery set-up screen, you can press **ENTER** to bypass this screen and go to the next user setup screen, or you can set the default Lithium battery type before moving on.

The Lithium Battery Select Screen

Here you can choose one of the three kinds of Lithium batteries supported by the X4 AC Plus, LiFe (3.3V), Lilo (3.6V) or LiPo (3.7V). If you plan to use one type of Lithium chemistry battery you can set the default here. **WARNING:** Make sure when you connect your battery that you have selected the proper type of battery before you begin charging your battery. Once you have established the desired settings press **Start/Enter** to confirm the setting then press **INC** to move on to the next parameter.

LiPo /Lilo/LiFe Check Time

To avoid an erroneous setting by the user the X4 AC Plus will automatically detect the cell count of a Lithium battery at the beginning of the charge or discharge process. To prevent an over-discharged battery from being detected incorrectly, resulting in an error, you can set a time limit for the processor to verify the cell count. The default setting is 10 minutes which is typically enough time to properly detect the cell count. It is not recommended that you change this setting as setting to long of a "Check Time" can produce dangerous results. Once you have established the desired settings press **Start/Enter** to confirm the setting then press **INC** to move on to the next parameter.

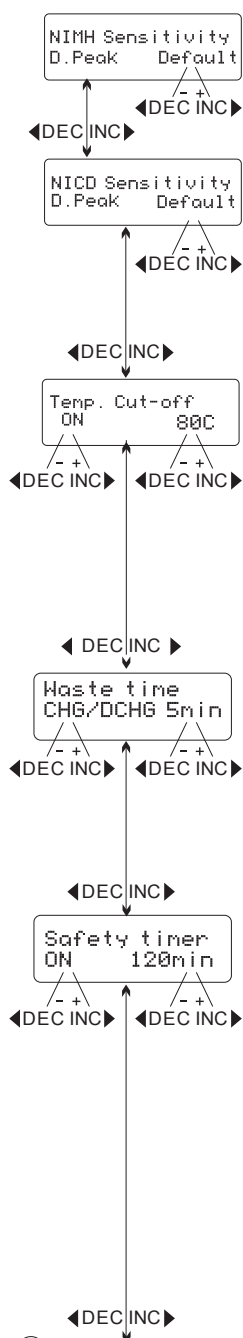

NiMH & NiCd Delta Peak Sensitivity Setting

This feature sets the cutoff voltage for the automatic charge termination of a NiMH and NiCd battery pack. The setting can range from 5 to 20mV per cell, the default is 12mV for NiCd batteries and 7mV for NiMH, the parameters are set individually for NiCd and NiMH batteries. If the cutoff voltage is too high, there is a danger of overcharging the battery, if it is too low there is a possibility of premature charge termination. Refer to the battery manufacturer's specifications to determine the proper setting. Once you have established the desired settings press **Start/Enter** to confirm the setting then press **INC** to move on to the next parameter.

Temperature Cutoff Setting

You can choose whether or not you want to use the automatic temperature cut off when using the optional temperature sensors. When turned on you can set the maximum temperature at which the charger should allow the battery to reach during charging. Once a battery reaches this temperature, the charge or discharge process will be terminated to protect the battery. Once you have established the desired settings press **Start/Enter** to confirm the setting then press **INC** to move on to the next parameter.

Waste Time Setting

When charge/discharge cycling a battery the battery will become warm. You can set a time delay ranging from 0 to 60 minutes after each charge/discharge process to allow the battery to cool down before starting the next charge/discharge cycle. Once you have established the desired settings press **Start/Enter** to confirm the setting then press **INC** to move on to the next parameter.

Safety Timer Setting

When the charge process starts, the integrated safety timer runs simultaneously. If an error occurs or the charge termination circuit cannot detect if the battery is fully charged, this setting will terminate the charge process to prevent overcharging. Use the Safety Timer Calculation below to determine the proper setting.

Safety Timer Setting Calculation

To determine the correct safety time setting when charging NiCd or NiMH batteries, divide the capacity by the current, and then divide the result by 11.9. Set the results of this calculation as the number of minutes for the safety timer setting. If the charger stops at this time threshold, about 140% of the capacity will have been fed into the battery. **Example:** 2000mAh 2.0A (2000/2.0=1000)/11.9=84 minutes.

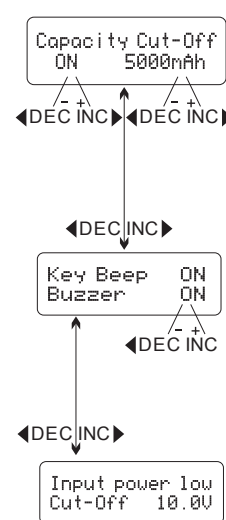

Capacity Cutoff Setting

The charging software allows the user to create a maximum charge capacity protection setting. If the delta-peak voltage is not properly detected or the safety timer times out, the charge process will stop automatically when the battery reaches the set maximum charge capacity set by the user. Once you have established the desired settings press **Start/Enter** to confirm the setting then press **INC** to move on to the next parameter.

Sound Settings (Key & Buzzer Mute)

A beep sounds to confirm the every time the user presses a button, additionally a sound is emitted during the operation of the charger to confirm a different mode change. These functions can be switched on or off. Once you have established the desired settings press **Start/Enter** to confirm the setting then press **INC** to move on to the next parameter.

Low Input Voltage Setting

This function monitors the input voltage of the DC power source used to power the charger. If the voltage is lower than the user setting, the program will end forcibly to protect the input source. Once you have established the desired settings press **Start/Enter** to confirm the setting. You have now set the initial user settings. You can repeat this procedure for the other Channels.

CONNECTING THE BATTERY

WARNING

Before connecting a battery, it is absolutely essential to check that you have set the parameters correctly. If the settings are incorrect, you can damage the battery and create a dangerous situation that could result in serious damage or injury.

Connecting the Battery

To avoid creating a short circuit between the banana plugs always connect the charge leads to the charger first, and then to the battery. Reverse the sequence when disconnecting the pack.

Connecting the Balancer Socket

These pictures show the correct way to connect your battery to the Hitec X4 AC Plus for charging in the balance mode. The balance socket attached to the battery must be connected to the charger with the black wire aligned with the negative marking. If your battery's balancer socket does not fit in the socket make sure to use the proper adapter board for you battery type.

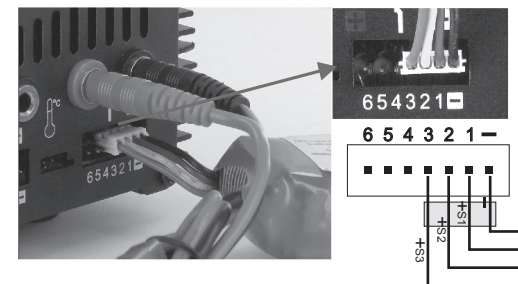

PROGRAM FLOW CHART

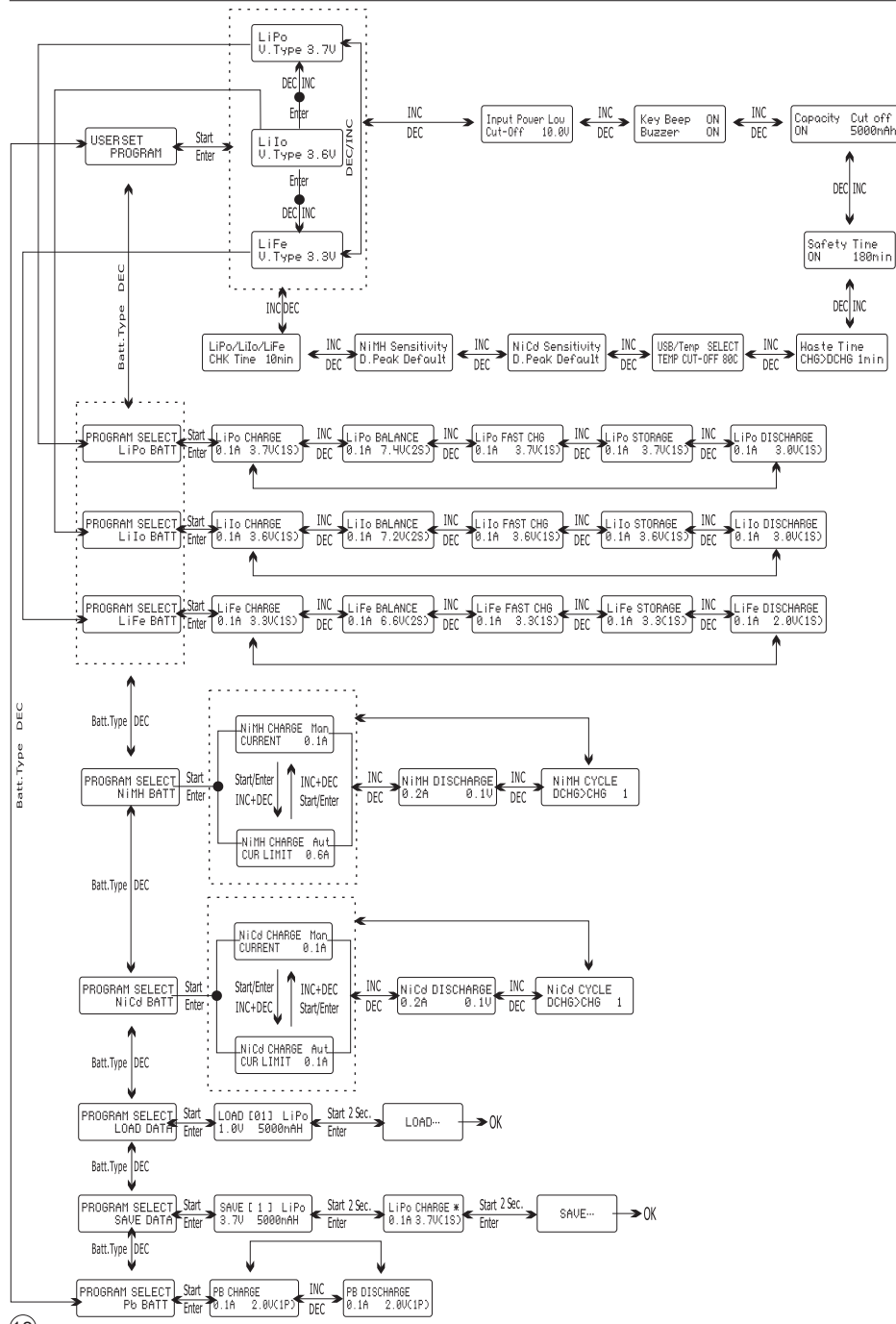

PROGRAM DISPLAY INFORMATION

You can view a variety of information on the LCD screen during the charge and discharge process. Press the **DEC** key to display and scroll through these settings. When connected to the balancing port you can monitor the voltage of each individual cell by pressing the **INC** key.

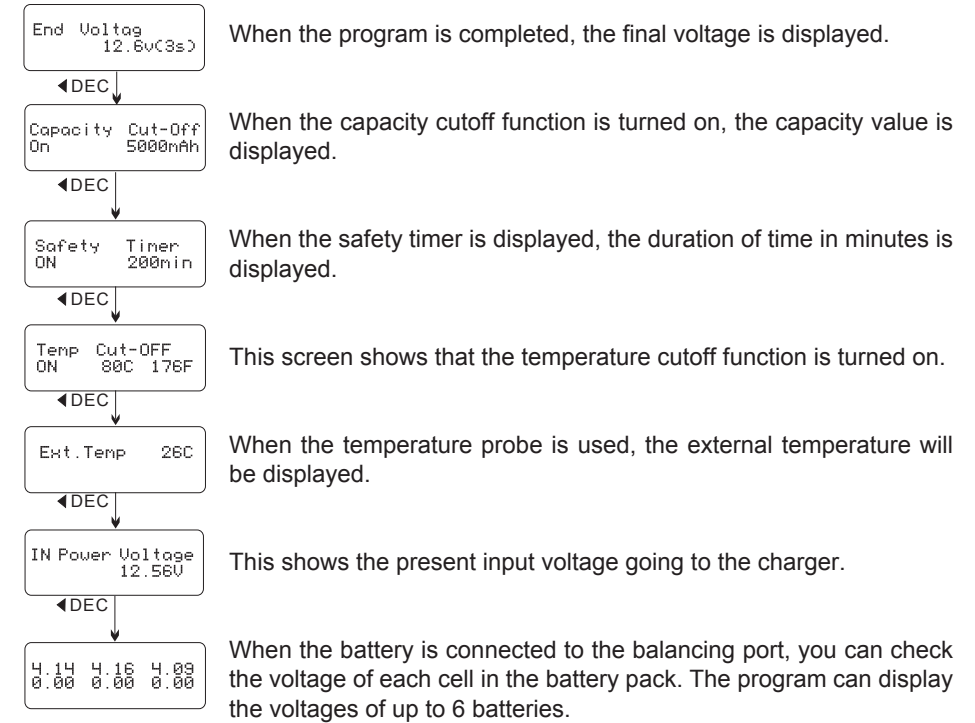

When the program is completed, the final voltage is displayed.

When the capacity cutoff function is turned on, the capacity value is displayed.

When the safety timer is displayed, the duration of time in minutes is displayed.

This screen shows that the temperature cutoff function is turned on.

When the temperature probe is used, the external temperature will be displayed.

This shows the present input voltage going to the charger.

When the battery is connected to the balancing port, you can check the voltage of each cell in the battery pack. The program can display the voltages of up to 6 batteries.

CHARGING LITHIUM CHEMISTRY (LiPo/LiIo/LiFe) TYPE BATTERIES

NOTICE

This program is only suitable for charging/discharging Lithium chemistry batteries. The X4 AC Plus was designed to only charge three kinds of Lithium batteries, Lithium Ferrite (LiFe), Lithium Ion (LiIo) and Lithium Polymer (LiPo). It is very important that you determine the type of battery you are charging and set the charging parameters correctly. It is important that the nominal voltage, final voltage, and battery capacity be properly set for desired operation. Please refer to the following information regarding the different types of Lithium chemistry batteries.

CHARGING LITHIUM CHEMISTRY (LiPo/LiIo/LiFe) TYPE BATTERIES

Lithium Ion (Li-Ion)

Nominal Voltage Level: 3.6V per cell
Max. Charge Voltage: 4.1V per cell
Allowable Fast Charge Current: 1C or less
Min. Discharge Voltage Cut Off Level: 2.5V per cell or higher

Lithium Polymer (Li-Po)

Nominal Voltage Level: 3.7V per cell
Max. Charge Voltage: 4.2V per cell
Allowable Fast Charge Current: 1C or less
Discharge Voltage Cut Off Level: 3.0V per cell or higher

Lithium Ferrite (LiFe)

Nominal Voltage Level: 3.3V per cell
Maximum Charge Voltage: 3.6V per cell
Allowable Fast Charge Current: 4C or less
Discharge Voltage Cut Off Level: 2.0V per cell or higher

NOTE

When you want to change the settings, press the **START/ENTER** key to make it blink, then use the **DEC** or **INC** key to change the setting. Then press the **START/ENTER** key again to store the setting.

Charging Lithium Battery in the Charge Mode

These methods for charging LiPo/Li-Ion/LiFe batteries without a balance lead.

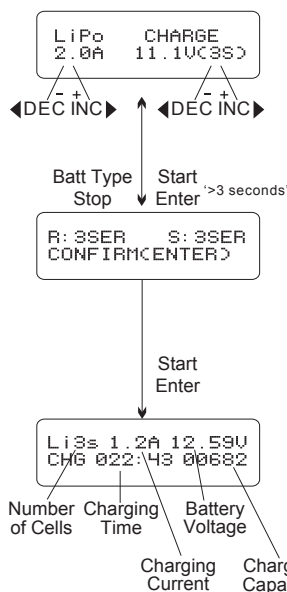

The first line on the left side of this screen shows the type of battery chosen. The second line shows the user set current on the left and the user set voltage on the right. After setting the current and voltage, press the **START/ENTER** key for more than 3 seconds to start the process (charge current range: 0.1-6.0A, voltage range: 3.7-22.2V).

The next display shows the number of cells you set up as "S" and the number of cells the processor detects as "R". If both numbers are identical, you can start charging by pressing the **START/ENTER** button. If not, press the **BATT TYPE/STOP** button to go back to the previous screen to carefully check the number of cells of the battery pack before proceeding.

This next screen shows the real-time status during the charge process. Press the **BATT TYPE/STOP** key once to stop the charge process.

CHARGING LITHIUM CHEMISTRY (LiPo/LiIo/LiFe) TYPE BATTERIES

Charging Lithium Battery in Balance Mode

This function is for balancing the voltage of Lithium-polymer battery cells individually while charging. In the balance mode, the battery needs to have a balance lead to connect to the balance port at the right side of the charger and the battery's power lead to the output of the charger. Charging in this mode is different from the normal modes because the built-in processor monitors the voltage of each individual cell and controls the input current fed into each cell in order to equalize the voltage.

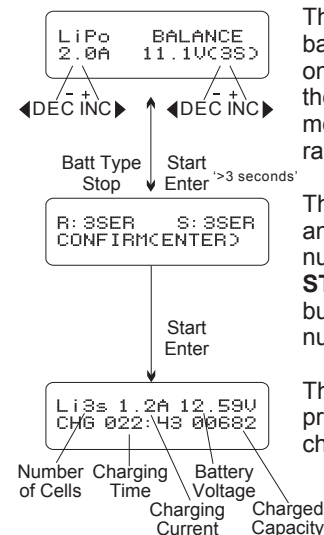

The first line on the left side of this screen shows the type of battery chosen. The second line shows the user set current on the left and the user set voltage on the right. After setting the current and voltage, press the **START/ENTER** key for more than 3 seconds to start the process (charge current range: 0.1-6.0A, voltage range: 3.7-22.2V).

The next display shows the number of cells you set up as "R" and the number of cells the processor detects as "S". If both numbers are identical, you can start charging by pressing the **START/ENTER** button. If not, press the **BATT TYPE/STOP** button to go back to the previous screen to carefully check the number of cells of the battery pack before proceeding.

This next screen shows the real-time status during the charge process. Press the **BATT TYPE/STOP** key once to stop the charge process.

Charging Lithium Batteries in Fast Mode

When charging lithium chemistry batteries in the fast charge mode the charging current will become lower towards the end of the charge cycle. In fast mode the charging capacity is slightly lower than in normal charge mode, but charging time is reduced.

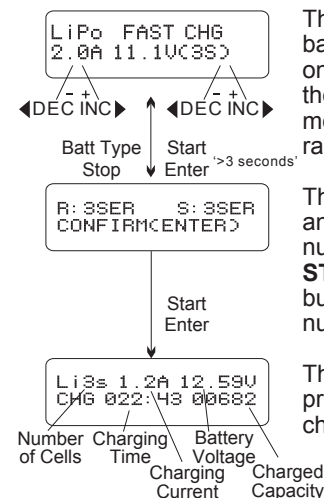

The first line on the left side of this screen shows the type of battery chosen. The second line shows the user set current on the left and the user set voltage on the right. After setting the current and voltage, press the **START/ENTER** key for more than 3 seconds to start the process (charge current range: 0.1-6.0A, voltage range: 3.7-22.2V).

The next display shows the number of cells you set up as "R" and the number of cells the processor detects as "S". If both numbers are identical, you can start charging by pressing the **START/ENTER** button. If not, press the **BATT TYPE/STOP** button to go back to the previous screen to carefully check the number of cells of the battery pack before proceeding.

This next screen shows the real-time status during the charge process. Press the **BATT TYPE/STOP** key once to stop the charge process.

CHARGING LITHIUM CHEMISTRY (LiPo/LiIo/LiFe) TYPE BATTERIES

NOTE

During the discharge process the X4 AC Plus's Microprocessor monitors the voltage of each cell during the Storage Mode or Discharge process. If the voltage of any cell is abnormal, the charger will display an error message and immediately terminate the program. Before disconnecting the battery review the error message then press the INC button to display which cell is.

Charging Lithium Batteries in the Storage Mode

The Storage Mode function is for charging/discharging batteries that will not be used immediately or that will be stored for a period of time. The program is designed for charging or discharging batteries to a specific voltage level depending on the type of battery (Li-ion = 3.75V, LiPo = 3.85V and LiFe = 3.3V) The program will begin to discharge if the original state of the battery exceeds the voltage level for storage.

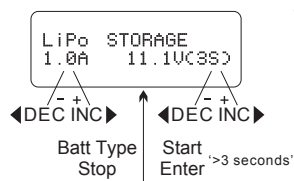

This screen, you can set up the current and voltage of the battery pack. Charging and discharging will bring the batteries to the storage level.

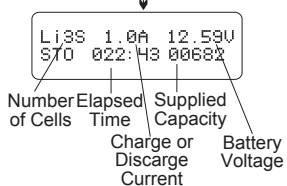

This screen shows the real-time status of the charge or discharge process. Press the **BATT TYPE/STOP** key once to stop the charging process.

Error Message Display

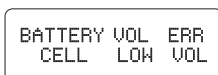

This screen shows that the processor detected the voltage of one on the cells is too low.

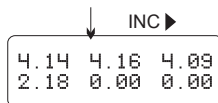

This screen shows the 4th cell was damaged. If the cell is disconnected or not present the reading of the voltage will be zero.

DISCHARGING LITHIUM CHEMISTRY (LiPo/LiIo/LiFe) TYPE BATTERIES

Lithium batteries are recommended to be discharged partially rather than fully. Frequent full discharging should be avoided if at all possible. Instead, charge the battery more often or use a battery of larger capacity. Full capacity cannot be reached until it has been subjected to 10 or more charge cycles. The cyclic process of charge and discharge will optimize the capacity of the battery pack.

DISCHARGING LITHIUM CHEMISTRY (LiPo/LiIo/LiFe) TYPE BATTERIES

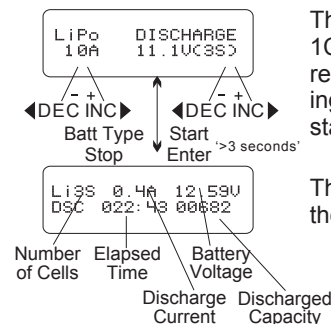

The setting of the discharge current on the left cannot exceed 1C, and the setting on the right cannot be under the voltage recommended by the manufacturer to avoid deep discharging. Press the **START/ENTER** key for more than 3 seconds to start discharging.

This shows the real-time status of discharging; you can press the **BATT TYPE/STOP** key to stop discharging.

Error Message Display

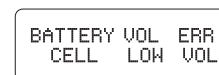

This screen shows that the processor detected the voltage of one on the cells is too low.

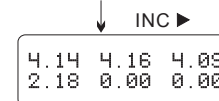

This screen shows the 4th cell was damaged. If the cell is disconnected or not present the reading of the voltage will be zero.

CHARGING/ DISCHARGING AND CYCLING NiCd OR NiMh BATTERIES

There are two methods of charging NiCd and NiMh batteries, Manual or Auto Mode. When in the NiMh or NiCd Program Select screen you can change modes by pressing the **START/ENTER** key until the current field begins flashing then press **INC** and **DEC** simultaneously to switch between Auto and Manual Mode. using the charge current you set up. In the "auto" mode, you should set the upper limit of the charge current to avoid damage caused by excessive charge current. This is especially important for low quality batteries that have low resistance and capacity. In the "manual mode" the charger will only charge at the current you set. Note the following charger / discharge specifications for NiCd and NiMh Batteries.

Nominal Voltage level: 1.2V/cell

Allowable Fast Charge Current: 1C-2C (depends on performance of cell)

Discharge Voltage Cut Off Level NiCd: 0.85V per cell

Discharge Voltage Cut Off Level NiMh: 1.0V per cell

Charging NiCd or NiMh Batteries

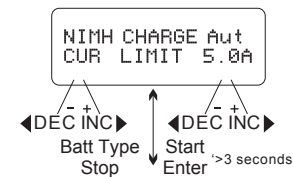

This program is for charging NiCd/NiMH batteries typically used in an R/C model application. Press the **START/ENTER** key until the parameter you want to change begins to blink then use the INC or DEC keys to change the value. Press the **START/ENTER** key to store the setting.

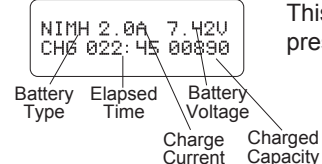

This screen shows the real-time status of charging. You can press the **BATT TYPE/STOP** key to stop the charge process.

CHARGING/ DISCHARGING AND CYCLING NiCd OR NiMh BATTERIES

Discharging NiCd or NiMh Batteries

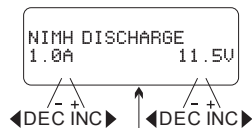

Set the discharge current on the left and the voltage cutoff on the right by pressing the **START/ENTER** key for more than 3 seconds to start the program. Discharge current can be set from 0.1-1.0A and voltage cutoff from 0.1-25.0V.



This screen indicates the discharging state. You can press the **START/ENTER** key to alter the discharge current. Press the **START/ENTER** key again to store the setting. Press the **BATT TYPE/STOP** key to stop discharging. The charger will emit a sound to indicate the end of the discharge process.

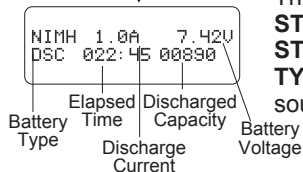

Charge/Discharge Cycling Of NiCd/NiMh Batteries

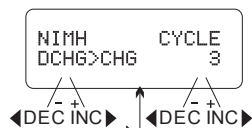

Set the cycle sequence on the left and the number of cycles on the right. The battery can be cycled 1-5 cycles.



Press the **BATT TYPE/STOP** key to stop the program then press the **START/ENTER** key to alter the charge or discharge current. A sound will indicate the end of the program.

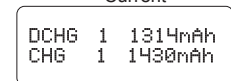
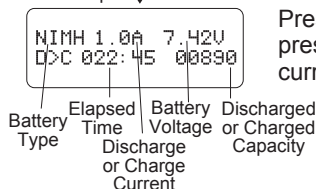

When the charger approaches the end of the program cycle, you can view the capacity of the battery being charged or discharged. Use the **INC** or **DEC** keys to scroll through the results of each cycle.

CHARGING / DISCHARGING LEAD-ACID (PB) BATTERIES

This program is only suitable for charging a lead-acid (PB) type battery with a nominal voltage range of 2 to 20 volts. Lead acid (Pb) batteries can only deliver current lower in comparison to their capacity. The same restriction applies to the charging process. Consequently, the optimum charge current for lead acid (Pb) batteries is only 1/10 of its rated capacity. You cannot fast charge lead acid (Pb) batteries. Please refer to the following specification regarding charging and discharging lead acid (Pb) batteries.

Nominal Voltage Level: 2.0V per cell

Maximum Charge Voltage: 2.46V per cell

Allowable Charge Current: 0.4C or less

Discharge Voltage Cut Off Level: 1.75V or higher per cell

CHARGING / DISCHARGING LEAD-ACID (PB) BATTERIES

NOTICE

Due to the chemistry characteristic of a Pb battery, the cut-off point may be difficult to detect at times. We recommend you use the **CAPACITY CUT-OFF** feature to protect the battery. Refer to the **Default User Preferences Setup** section of this manual to set up this feature.

Charging Lead Acid (Pb) Batteries

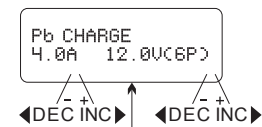

Set the charge current on the left and the nominal voltage on the right. Charge current can be set from 0.1-6.0A. The voltage must match the battery being charged. Press the **START/ENTER** key for more than 3 seconds to start charging.

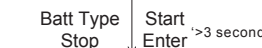

The screen will display the real-time charging status. Press the **START/ENTER** key to alter the charge current. Press the **START/ENTER** key again to store the parameter settings you set. Press the **BATT TYPE/STOP** key to end the program.

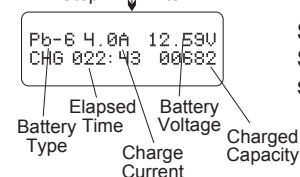

Discharging Lead Acid (Pb) Batteries

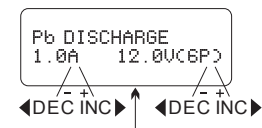

Set up the discharge current on the left and the nominal voltage on the right. The discharge current can be set from 0.1-1.0A. The voltage should match the battery being charged. Press the **START/ENTER** key for more than 3 seconds to start discharging.

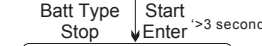

The screen displays the real-time discharging status. Press the Start/Enter key to alter the discharge current. Press the Start/Enter key again to store the parameter value you set. Press the **BATT TYPE/STOP** key to end the program.

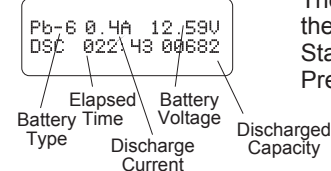

BATTERY DATA PRESET STORAGE AND LOAD FEATURE

For your convenience, the X4 AC Plus has a data storage and load program that can store up to five preset battery charge or discharge configurations. You can recall these settings when charging or discharging without having to setup the program again. To get to the save data screen press the **BATT. TYPE/ STOP** button until you see the Save Data screen. Press the **START/ENTER** key to modify the menu, and use the **INC** or **DEC** to change the parameters.

Save Data Program

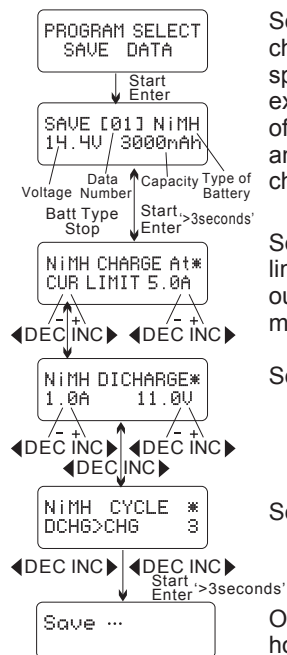

Setting of the parameters in the first screen will not affect the charge and discharge process. It is only for identifying the specification of the battery you will create a preset for. In this example it is a NiMH battery pack with 12 cells and a capacity of 3000mAh. When you have completed this process press and hold the **START/ENTER** key for 3 seconds to enter the charge/discharge setup screen.

Set up the charge current in the manual mode, or the current limit in the auto mode. Press the **INC** and **DEC** key simultaneously to make the current field blink to switch the charge mode.

Set up the discharge current and cutoff voltage.

Set up the charge/ discharge sequence and cycle number.

Once you have completed the setup procedures press and hold the **START/ENTER** key for 3 seconds to save the data.

Load Data Program

This program is designed to load the data stored in the “save data” program. To get to the save data screen press the **BATT. TYPE/ STOP** button until you see the Load Data screen Press the **START/ENTER** key to make the data field blink and press the **INC** or **DEC** keys for at least 3 seconds to load the data.

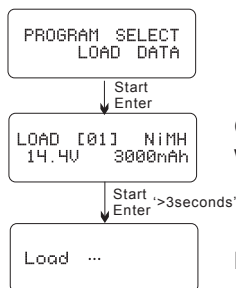

Choose the data number you want to call back. The data you want to call back will be displayed.

Load the data.

WARNING AND ERROR MESSAGES

The X4 AC Plus incorporates a variety of systems to verify the various charge/discharge processes and the overall state of the electronics. In case of an error, the charger will emit an audible alarm and the screen will display the cause of the error. See the following description of the errors and their possible causes.

REVERSE POLARITY	Incorrect polarity connected.
CONNECTION BREAK	Battery connection is interrupted.
SHORT ERR	Short circuit on the battery connection.
INPUT VOL ERR	Incorrect input voltage.
VOL SELECT ERR	The voltage of the battery pack has been incorrectly set.
BREAK DOWN	The charger has malfunctioned for some reason. Contact the Hitec RCD USA customer service department immediately.
BATTERY CHECK LOW VOLTAGE	The voltage is lower than which is set, check the number of cells in the battery pack.
BATTERY CHECK HIGH VOLTAGE	The voltage is higher than which is set, check the number of cells in the battery pack.
BATTERY VOLTAGE CELL LOW VOL	The voltage of one cell in the battery pack is too low, check the voltage of each cell.
BATTERY VOLTAGE CELL HIGH VOL	The voltage of one cell in the battery pack is too high, check the voltage of each cell.
BATTERY VOL ERR CELL CONNECT	An improper connection to the battery is detected, check the connectors to insure they are properly connected.
TEMP OVER ERR	The internal temperature of the charger is too high. Allow it to cool down by discontinuing use.
CONTROL FAILURE	The processor cannot control the output current, take corrective action immediately or contact the Hitec RCD USA customer service department.

RECOMMENDED ACCESSORIES

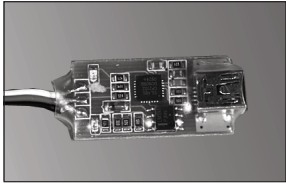

P.C. Link Adapter
PN: 44168



Temperature
Sensor Cable
PN:44159

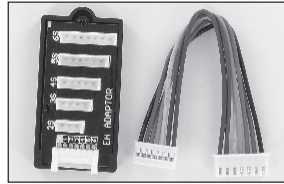

EH Adaptor
PN:44154

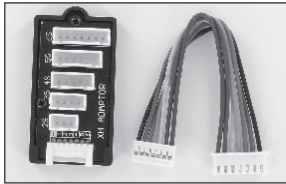

XH Adaptor
PN:44155

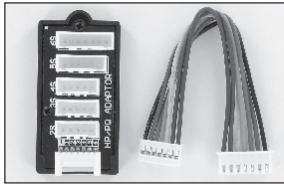

HP/PQ Adaptor
PN:44153

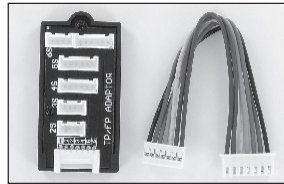

TP/FP Adaptor
PN:44152

CONFORMITY AND REGULATORY INFORMATION

The Hitec X4 AC Plus satisfies all relevant and mandatory FCC and EC regulatory directives including the following.

	Test Standards	Title	Result
CE-LVD	EN60335	For safety of household and similar electrical appliances.	Conform
CE-EMC	EN 55014-1:2006	Electromagnetic compatibility-Requirements for household appliances,electric tools and Similar apparatus - Part 1: Emission	Conform
	EN55014-2:1997 +A1:2001	Electromagnetic compatibility-Requirements for household appliances,electric tools and Similar apparatus - Part 2: Immunity-Product family standard	Conform
	EN61000-6-1(2007)	Electromagnetic compatibility (EMC) -- Part 6-1: Generic standards - Immunity for residential, commercial and light-industrial environments.	Conform
	EN61000-6-3(2007)	Electromagnetic compatibility (EMC) -- Part 6-3: Genericstandards - Emission standard for residential, commercial andlight-industrial environments.	Conform
FCC-VOC	FCC Part 15B	Electromagnetic compatibility (EMC), Conduction Emission & Radiation Emission.	Conform



This symbol means that when any type of electronics reaches the end of its life it cannot be disposed with normal household waste and must be recycled. To find a recycling center near you refer to the internet or Yellow Pages under electronic waste recyclers.

STATE OF CALIFORNIA PROP 65 WARNING

This product contains chemicals known to the State of California to cause cancer. Use caution when handling this product and avoid exposure to any electronic components or internal assemblies.

WARRANTY AND SERVICE INFORMATION

ONE YEAR LIMITED WARRANTY

For a period of one year from the date of purchase HITEC RCD USA, INC. shall REPAIR OR REPLACE, at HITEC RCD, INC. option, defective equipment covered by this warranty, otherwise the purchaser and/or consumer is responsible for any charges for the repair or replacement of the radio. This warranty does not cover cosmetic damages and damages due to acts of God, accident, misuse, abuse, negligence, improper installation, or damages caused by alterations by unauthorized persons or entities. This warranty only applies to the original purchaser of HITEC RCD, INC. products purchased and used the products in the United States of America, Canada and Mexico. Batteries, plastic cases and gears are not covered by this warranty.

THIS WARRANTY IS IN LIEU OF ANY AND ALL OTHER WARRANTIES, WHETHER FOR MERCHANTABILITY OR FITNESS FOR A PARTICULAR PURPOSE AND WHETHER EXPRESS OR IMPLIED. REPAIR OR REPLACEMENT AS PROVIDED UNDER THIS WARRANTY IS THE EXCLUSIVE REMEDY. HITEC RCD, INC. SHALL NOT BE LIABLE FOR ANY INCIDENTAL OR CONSEQUENTIAL DAMAGES FOR BREACH OF ANY EXPRESS OR IMPLIED WARRANTY RELATING TO THIS PRODUCT. EXCEPT TO THE EXTENT PROHIBITED BY APPLICABLE LAW, ANY IMPLIED WARRANTY OF MERCHANTABILITY OR FITNESS FOR A PARTICULAR PURPOSE ON THIS PRODUCT IS LIMITED IN DURATION TO THE DURATION OF THIS WARRANTY.

Some states do not allow the exclusion or limitation of incidental or consequential damages, or allow limitations on how long an implied warranty lasts, so the above limitations may not apply to you. This warranty gives you specific legal rights, and you may have other rights which vary from state to state.

REPAIR AND SERVICING

To have your Hitec X4 AC Plus Serviced follow these instructions.

1. Visit the Hitec RCD USA website and download the service request form.

<http://www.hitecrd.com/files/serviceform.pdf>

2. Complete the service request form in its entirety and include a COPY of your original receipt showing the purchase date.
3. PACKAGE YOUR RETURN IN ITS ORIGINAL PACKAGING OR USE A TOTAL SUSPENSION TYPE PACKAGING (FOAM PEANUTS OR NEWSPAPER). HITEC RCD SHALL NOT BE RESPONSIBLE FOR GOODS DAMAGED IN TRANSIT.

4. Ship prepaid (COD or postage due returns will be refused) via a traceable common carrier (UPS, insured parcel post, FED EX, etc.) TO:

Hitec RCD USA, Inc.
Customer Service Center
12115 Paine St.
Poway, CA 92064

