

3 CHANNEL COMPUTER RADIO CONTROL SYSTEM
AGGRESSOR
SRXPRO



2.4GHz & PPM Module
 Compatible



High-Response Mode



Smart-Link

2.4GHz & PPM Module Compatible

SRX-Pro can be used with both conventional (PPM type) modules and 2.4GHz DSSS module. It will give you the freedom of unnecessary conversion of all the conventional system you have.

You can still race with both conventional and 2.4GHz systems by simple change of the module.

High-Response Mode

Hitec's upgraded technology, H-RSP (High Response) function gives you more accurate control and rapid response just as your vehicle bonded to your mind. Our 7ms response time is more than enough to make you feel like you are in the vehicle actually driving it.

Smart-Link

Hitec's 2.4GHz Smart-Link system promises you to be free from conventional crystal type frequency hunting. Simply press the button, turn on both receiver and the radio, then you are all ready to go.



CE06810

35MHz-40MHz Band for use in:
 AT, BE, BG, CH, CY, CZ, DE, DK, EE, ES,
 FI, GB, GR, HU, IE, IT, LT, LU, LV, MT, NL,
 PL, PT, RO, SE, SI, SK

CE06780

2.4GHz Band for use in:
 AT, BE, BG, CH, CY, CZ, DE, DK, EE, ES,
 FI, GB, GR, HU, IE, IT, LT, LU, LV, MT, NL,
 PL, PT, RO, SE, SI, SK, FR

Made in the Philippines

Ver 1.0

HITEC



3 CHANNEL COMPUTER RADIO CONTROL SYSTEM
AGGRESSOR
SRXPRO

HITEC DIRECT SEQUENCE SPREAD SPECTRUM
2.4GHZ DSSS

3 Channel Pistol Type Computer Radio

2.4GHz(DSSS) & FM Ready

3rd Channel Button for Shift/ Linear/ Idle-Up Function

H-RSP(High Response) mode

Quick Program Access

10-Model Memory with Individual Naming

www.hitecrd.com

HITEC



Table of Contents

I. Introduction	2
II. Features & Specification	2
A. Designation	3
1. Transmitter/Module/Receiver	
B. Specification of SRX Pro	7
1. Transmitter/Module/Receiver/Servo/Accessories	
III. Installation & Setup	9
A. Battery Installation	9
*Battery Recharging	
B. Module and Receiver Installation	10
1. Module Installation	10
2. Receiver Installation	11
3. Receiver Connection Diagrams	12
a. Gas Powered Vehicles	
b. Electric Powered Vehicles	
4. Link(ID-Setting) Method	13
5. Fail-Safe/Hold Mode setup	15
IV. Functions and Operations	17
A. Instant Adjustment Functions	17
1. Digital Trims	17
2. Third Channel Button	17
3. D/R (Dual Rate) Adjustment Dial	18
4. ATL Function	19
B. Main Menu	19
1. Model Select	20
2. Model Reset	20
3. Model Naming	21
4. H-RSP Mode Select	21
5. Third Channel Button Setup	22
6. Timer Setup	23
C. Programming Menu	24
1. Sub-Trim Adjustment	25
2. End Point Adjustment	26
3. Exponential Rate Adjustment	27
4. Servo Rotation Adjustment (Reverse/Normal)	28
5. Idle-Up/Shift/Linear Setup	29
V. Warnings	29
VI. Troubleshooting Guide	30

I. Introduction

We sincerely appreciate your purchase of the Aggressor SRX-Pro. The Aggressor SRX-PRO is loaded with the same great features of SRX plus a few new features. Please read this manual carefully to maximize your R/C driving experience.

II. Features & Specification

A) Radio Features

- Ergonomically Designed 3-Channel Pistol Grip Computer Radio System
- Module Swapping Type for Easy Frequency Changing & 2.4GHz
- Dual Rate Steering (Adjustable on the drive)
- Brake ATL Switch (Adjustable Travel Length)
- Brake Lever Travel Limiter
- Steering Wheel Tension Adjustment
- Digital Trims (Steering / Throttle & Brake / Linear Control)
- Trim Center Audible Verification
- Third Channel Button (Idle Up / Shift)
- Interchangeable Assorted Color Rubber Grip Pads in Two Sizes (Sold Separately)
- Foam Steering Wheel for Comfortable Control
- Transmitter Charging Jack for Optional Rechargeable Batteries
- LED Indicator Light
- Low Battery Warning Alarm
- 2.4 GHz Ready
- H-RSP (High Response: 7ms) Servo Control and Normal Response(14ms) Selectable

B) Programmable Features

- Up to four characters model naming
- Ten different models to save
- Sub-Trims
- Variable use for the third channel Switch Set (Shift, Linear, or Idle-up)
- End Position Adjustment (EPA)
- Exponential Travel (Steering, Throttle, and Brake)
- Timer
- Servo Reversing
- Model Reset (Factory Default)

A. Designation

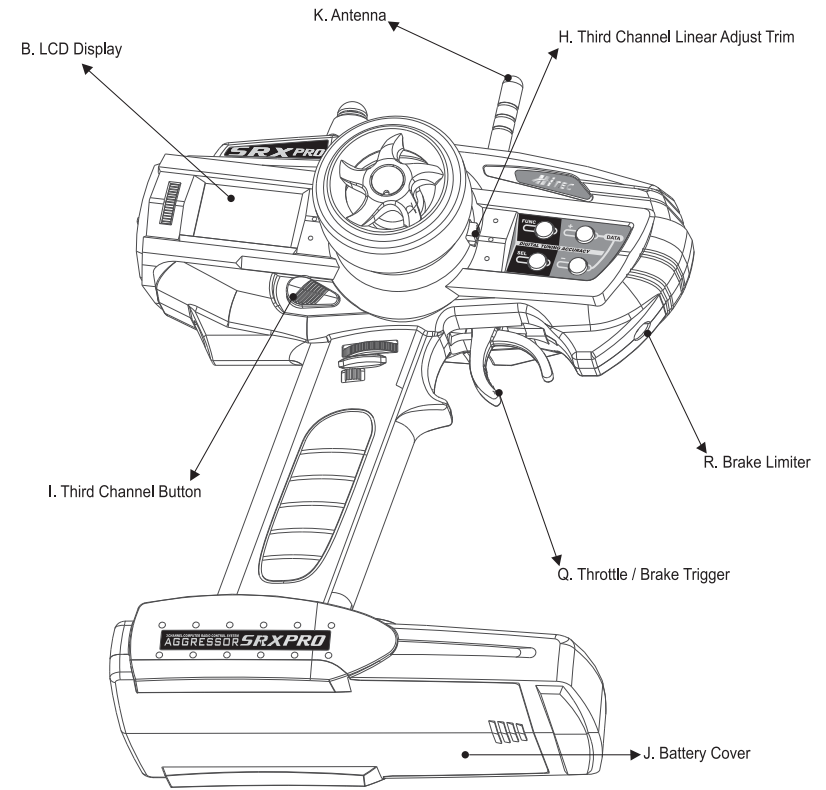
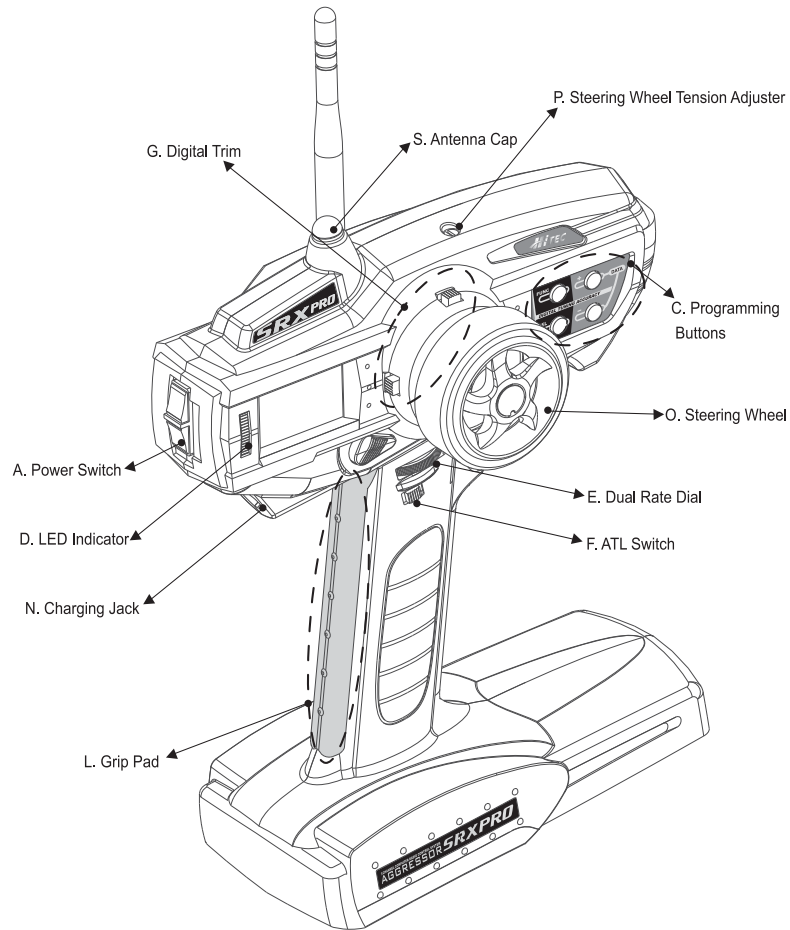

A) Power Switch

- Slide the switch up to turn the transmitter on, and down to turn it off.

Warning: Always turn your transmitter on first and off last to prevent accidental runaways.



B) LCD Display

1. Model Name
2. Battery voltage & meter
3. Current mode indicator

C) Programming buttons

- "FUNC" Function button
- "SEL" Select button
- "+" Increase data value
- "-" Decrease data value

D) LED Status Indicator

- The green light will turn on when the power is on.
- Slow flashing LED light indicates its Idle up function is on.
- Fast flashing LED light indicates its battery level is low.

E) Steering Dual Rate

- Adjusts the overall travel of the steering servo.
- Scroll the dial forward with your thumb for maximum steering (Maximum 125%).
- Scroll the dial backward with your thumb to reduce the travel (Minimum 60%).
- Use this to fine tune your vehicle's handling for the surface conditions.
- Use more steering rate for high grip surfaces and less for low grip surfaces.

F) Actual Travel Length (ATL) Switch

- Adjusts the brake servo or ESC (Electronic Speed Control) travel end position.
- Push the switch forward with your thumb for maximum braking (Maximum 100%).
- Pull it back to reduce the braking power (Minimum 0%).

Note: Be aware that at 0% you will have no brakes.



G) Digital Trim (Steering and Throttle Trims)

- These trims are used to fine-tune the point where the servo returns to center.
- Adjust the ST-TRIM so your vehicle travels perfectly straight when the steering wheel is centered.
- Note: If you move the trim to its maximum and the vehicle does not go straight, move the servo horn on the servo output spline or adjust the sub-trim to fix the problem.
- Use the THR-TRIM to adjust the "Drag Brake" or "Coast Brake"; this is the amount of braking that occurs when the trigger is at neutral.

Note: Do not mount the horn on the servo until you turn on the radio and center the trims and sub-trims. Always check your trims before you drive or race.



H) Third Channel Linear Adjust

- Used to adjust the AUX servo to any position.

Note: This feature is typically used for a mixture control in nitro boats.



I) Third Channel Button

- Shift Function: Use the button to shift gears (High/Low or Forward/Reverse) in vehicles like the T-Maxx and others.
- Idle-up Function: Use the button to increase the idle for Nitro and Gasoline vehicles.

Note: You can adjust the overall travel with the AUX EPA (End Position Adjustment)



J) Battery Cover

- It protects batteries from shocks, dust, and fall off.

K) Antenna

- Always extend your antenna before turning your transmitter on.
- Even though the performance of transmitter is the same, it is recommended to remove the antenna, in order to use a 2.4GHz module.
- The antenna can be removed by turning counterclockwise.
- Warning: When collapsing your antenna, never push it from the top; it may bend.

L) Grip Pad

- The removable grip pad helps keep your hand secure on the radios pistol grip handle.
- The Grip Pads are available in assorted colors and sizes to customize the look and feel of your radio.

M) Module

- The replaceable module located in the back of the transmitter contains the frequency crystal and frequency band of the radio.
- Crystals may be interchanged if permitted.
- The Spectra module will allow any channel to be selected within the 75MHz band without the crystals.
- The Spectra synthesized module can be purchased separately.
- 2.4GHz module is used for SRX-PRO, and it also can be purchased separately.
- To remove the module, press the tabs with your thumb and finger while pulling it outward.

Note: Wiggle the module to help ease its removal.



N) Charging Jack

- The transmitter charging jack located under the power switch is for use with the Hitec optional CG-25 charger. The charger can be purchased separately if using rechargeable batteries.
- (See "Recharging Batteries" for more information about this feature.)

Warning: Do not attempt to charge alkaline and other dry cell batteries; they may explode.



O) Steering Wheel

- Used to control the steering of your vehicle.

P) Steering Tension Adjustment

- Used to tighten or loosen the tension of the steering wheel.

Q) Throttle Trigger

- Used to control the throttle and braking of your vehicle.
- Pull the trigger for throttle and push it forward for braking or reverse when using a reversing Electronic Speed Control.

R) Brake Limiter

- Used to limit the physical "braking travel" of the trigger.

S) Antenna Cap

- When 2.4GHz system is used, Antenna cap will prevent dust to enter inside of conventional Frequency Antenna Slot of SRX-Pro.

B. Specification of SRX Pro

i. Transmitter Module & Receiver

- Power Output: 300mW
- Capital Drain: 190mA
- Modulation: FM/PPM, DSSS(Digital Sequencing Spread Spectrum)
- Power Supply: 8-AA Sized Alkaline, Ni-Cd(NiCad) or Ni-MH Batteries
- Frequencies: 40MHz, 75MHz, 2.4GHz

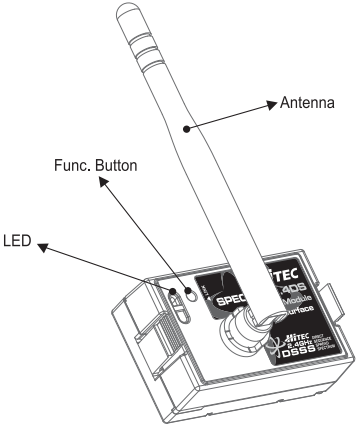

<Spectra 2.4DS (MODULE)>

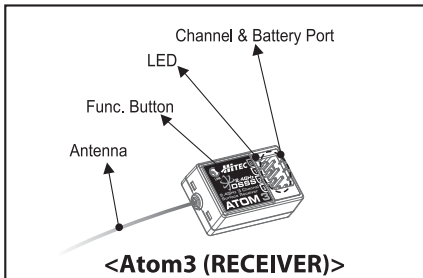

<Atom3 (RECEIVER)>

Channel	3 CH
Modulation	2.4GHz DSSS
Operating Voltage	4.5-7.4V (available LiPo 2cells)
Size	31 x 19 x 12 mm
Weight	6.8g (0.24oz)

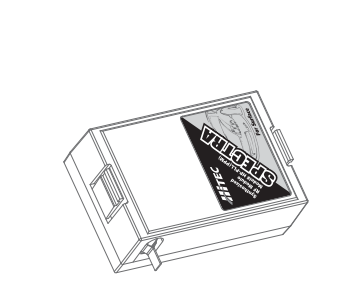

<Spectra FM (MODULE)>

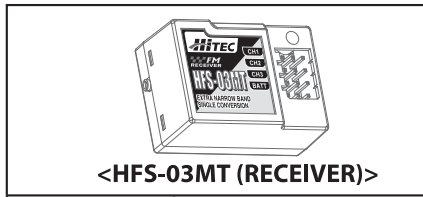

<HFS-03MT (RECEIVER)>

Channel	3 CH
Modulation	FM/PPM, Single Conversion
Operating Voltage	4.8 – 6.0V
Size	36.7 x 25 x 18 mm
Weight	15g (0.53oz.)

ii. Servo

HS-5485HB
 DIGITAL STANDARD

4.8 V Torque : 5.2 kg.cm
 4.8 V Speed : 0.20 sec/60°
 6.0 V Torque : 6.4 kg.cm
 6.0 V Speed : 0.17 sec/60°
 Dimensions : 39.8 x 19.8 x 38 mm
 Weight : 45 g
 Stock# 35485



HS-325HB
 DELUXE

4.8 V Torque : 3 kg.cm
 4.8 V Speed : 0.19 sec/60°
 6.0 V Torque : 3.7 kg.cm
 6.0 V Speed : 0.15 sec/60°
 Dimensions : 40 x 20 x 36.5 mm
 Weight : 43 g
 Stock# # 33325



iii. Accessories

- Finger Tip Brake Pad
- Rubber Grip Pads in Blue, Red, and Black
 Small: Part # 54309
 Large: Part # 54310
- 1600mAh Ni-MH Rechargeable Battery: Part # 54115
- Overnight Wall Charger: Part # 43025

iv. Available Versions

- 2.4GHz DSSS Version
 - Standard Version: Part # 13241
 SRX-Pro, Spectra 2.4DS, Atom 3, HS-5485HB x 2, Alkaline Battery Tray
 - No Servo Version: Part # 13240
 SRX-Pro, Spectra 2.4DS, Atom 3, Alkaline Battery Tray
- Conventional Frequency Version
 - Standard Version A: Part # 130400 (40MHz)
 SRX-Pro, HP-MIC 40MHz, Spectra Pro Car HFS-03MT, HS-325HB x 2, Alkaline Battery Tray
 - No Servo Version: Part # 129753 (75MHz Only)
 SRX-Pro, HP-MIC 75MHz, HFS-03MT, Alkaline Battery Tray

III. Installation & Setup

A. Battery Installation

- Press down on the battery cover and slide in the direction illustrated.
- Remove the cover and install the batteries as shown.
- Remember to be careful and pay close attention to the polarity of each cell you you could damage the transmitter.
- Replace the cover; making sure it is closed securely.

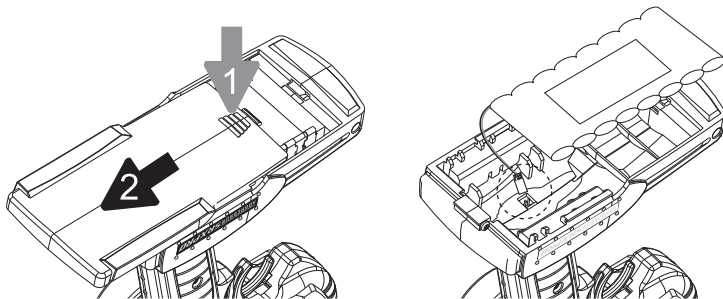

*Battery Recharging

- Connect the Hitec's genuine overnight wall charger* (sold separately) to the transmitter charging jack located under the transmitter power switch to charge optional re-chargeable batteries.

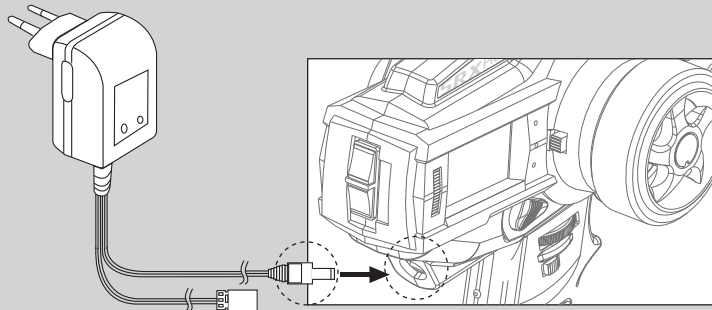

Note: If the charger is correctly hooked up to the transmitter, the red light on the charger will be lit while it's charging. If it is not, check the connection or the battery.

- The CG-25 can also charge four (4) cell receiver batteries up to 1000mAh through the other output pigtail of the charger. Simply plug the connector into the receiver battery pack or the charge port of the on/off switch if applicable.

Note: If the charger is correctly hooked up to the receiver battery, the green light on the charger will be lit while charging. If it is not, check the connection or the battery.



- A full charge on the supplied transmitter Ni-Cd and Ni-MH battery pack will take 12-16 hours.

Warning: Do not attempt to charge alkaline batteries; they may explode.



* Hitec's genuine overnight wall chargers sold separately as CG-S32 for the Europe and CG-25A for North America

B. Module and Receiver Installation

1. Module Installation

Aggressor SRX Pro can be used with conventional frequency module (HP-MIC/HP-PLL) and 2.4GHz DSSS module (Spectra 2.4DS).

HP-MIC/HP-PLL

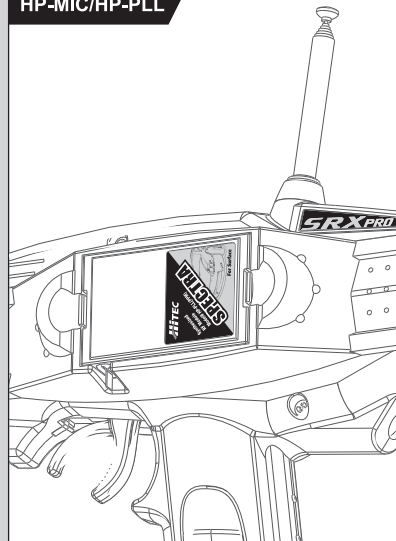

Spectra 2.4DS

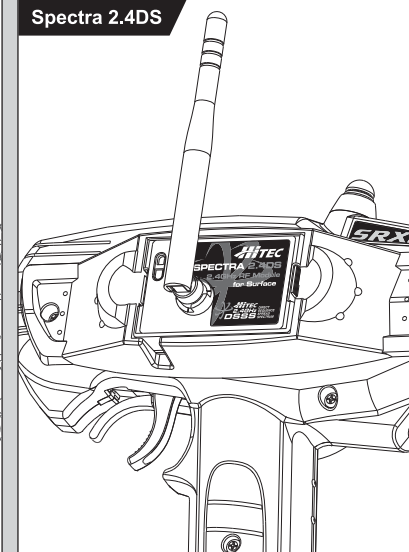

2. Receiver Installation

Depending on your preferences, you can choose either conventional frequency system (HFS-03MT) or 2.4GHz system (Atom 3).

We recommend to use wrapping sponge pad or thick double sided tape to protect the system from the shock during its operation.

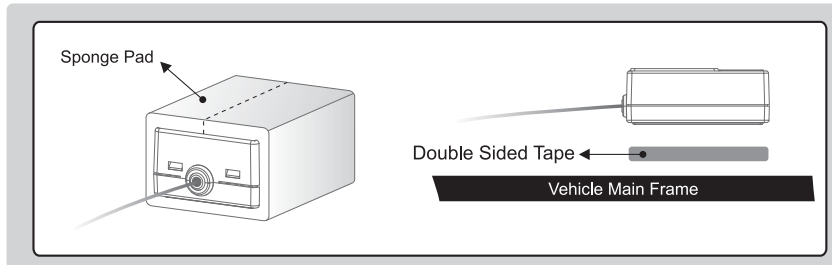

Warnings

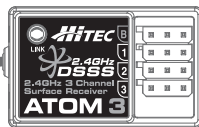

Never cut the antenna, such behavior will seriously reduce the reception range.

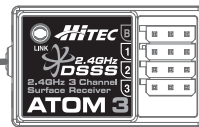
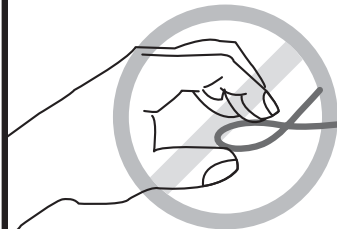

Never pinch or bend the antenna, such behavior will cause serious damage on the antenna.

3. Receiver Connection Diagrams

A. Glow, gas or electric powered vehicle using a separate receiver battery supply.

Follow this connection diagram when using a dedicated 4.8 to 6.0V. Ni-MH, Ni-Cd battery pack, or *2S Li-Po/Li-Fe batteries.

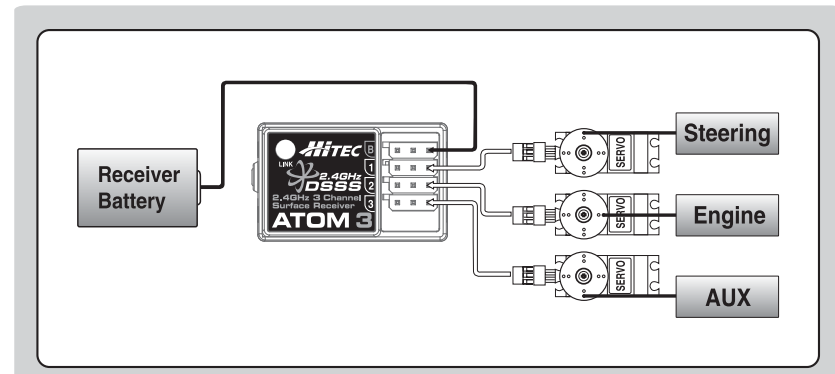

B. Electric Powered Vehicles

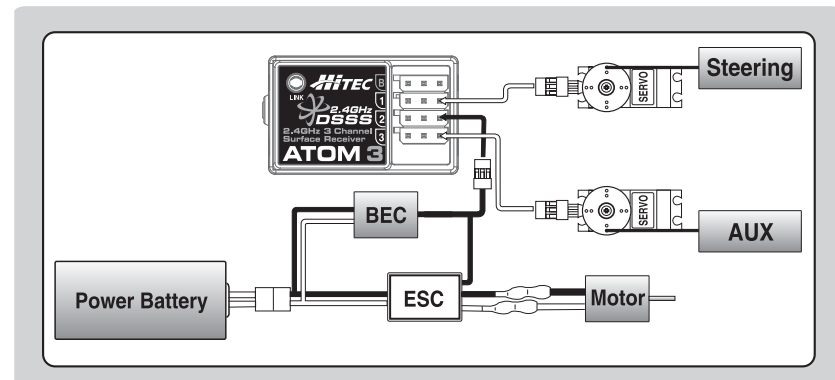

4. Link (ID-Setting) Method

Your Hitec Spectra 2.4DS (2.4GHz DSSS system) uses a synchronized protocol and binds the Atom 3 receiver to your transmitter. Once the receiver and module are "bound", no other transmitter can interfere with your receiver during its operation.

In the case of multiple model memory transmitters, you can bind as many Atom 3 receivers to your transmitter as necessary. Each module and receiver set is paired at the factory for your convenience.

Note: If purchased separate Atom 3, the Link (ID-Setting) process is required.

How to Link additional receivers:

Please refer to the connection diagram and connect all the necessary items before the process.

Note: To avoid any interference, the link process should be done within 3 feet (1 meter) in distance.

How to Link Spectra 2.4DS and Atom 3 receivers:

Atom 3 receiver

1 Press and hold the function button and turn on the power.

Release the button

2

Confirm the red LED is blinking.
The receiver is waiting for incoming signal.

3

Once the receiver's link (ID-Setting) process done.
The red LED will stop blinking and become steady on status.

4

Spectra 2.4DS

1 Press and hold the function button and turn on the power.

2 Release the button the red LED will blinking and looking for a receiver.

3 Confirm that the receiver's red LED is solid on.

4 Turn off receiver first then the transmitter power..

5 Turn on receiver first then the transmitter power.

Now you are ready to run. 🎵

5. Fail-Safe/Hold Mode setup

What is Fail-Safe Mode?

If you use the FAIL-SAFE function, and set it up properly, should the receiver signal somehow be interrupted or interference were to occurred, the servos will move to your pre-set FAIL-SAFE position you previously stored in the receiver during the FAIL-SAFE set-up.

If FAIL-SAFE has not been activated, the signal is switched off after the HOLD period of 1 sec. This means that the servos become "soft" and remain in their last commanded position under no load (this may equate to full-throttle!), until a valid signal is picked up again.

In the interests of safety, we recommend that FAIL-SAFE should always be activated, and the FAIL-SAFE settings should be selected so as to bring the model to a non-critical situation (e.g. motor idle / electric motor OFF, control surfaces neutral, or full brake, etc.)

Fail-Safe Setup Method:

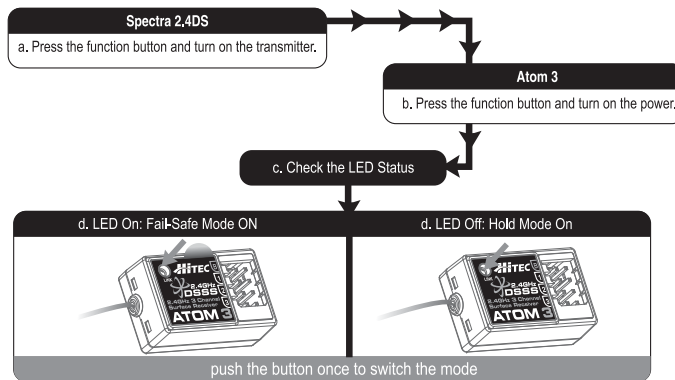

When LED Off (Hold Mode On):

To switch to the Fail-Safe Mode, first adjust all the control knobs to the fail-safe position you prefer, then press the function button once, the LED turns on at the same time the fail-safe position will be saved.

When LED On (Fail-Safe Mode On):

Press the function button once to switch to the hold mode, the LED will go off and indicates that the receiver is in Hold Mode.

Note: once you switch to the hold mode all the saved Fail-Safe position will be deleted.

Once Fail-Safe/Hold Selection Mode activated, you can keep switching the mode by pressing the function button.

**NOTE: If FAIL-SAFE is deactivated, the FAIL-SAFE position settings are also deleted!
 The FAIL-SAFE settings should be checked every time before you run the engine/motor.**

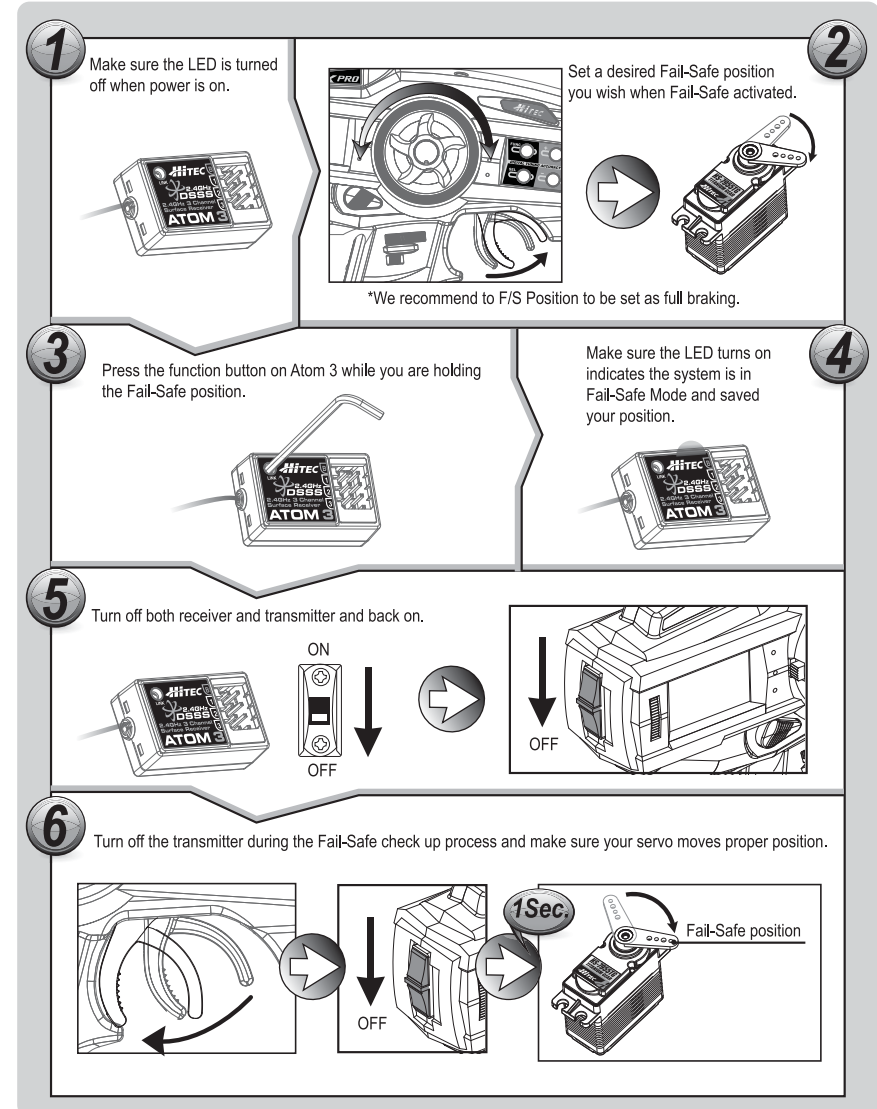

IV. Functions and Operations

A. Instant Adjustment Functions

1. Digital Trims

Digital Trims can give you a fast access of servo adjustment during the racing.

This function is less delicate than Sub-Trim adjustment. To make a fine adjustment of a servo please use Sub-Trim adjustment (pg. 25)

Note: Sub-Trim adjustment is about three times more delicate than D-Trim adjustment

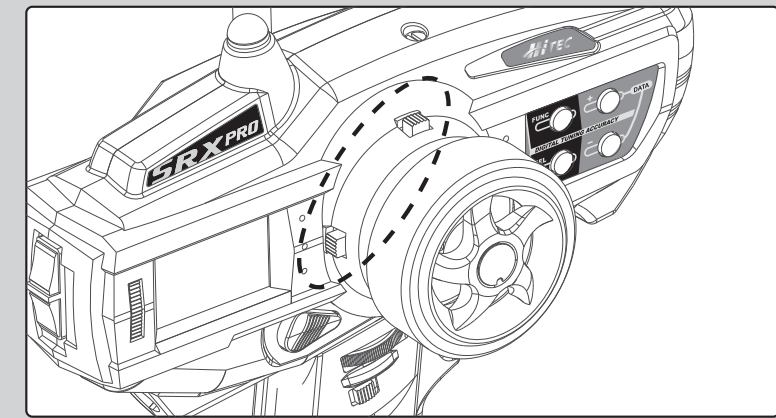

2. Third Channel Button

Use Third Channel Button to perform Shift and Idle-Up function.

Shift function can be found very useful for a vehicle equipped with gearbox (forward & reverse), such as T-Maxx and Revo, etc. The Idle-Up function can be used for any nitro & gasoline vehicle to keep the idle high at start up, refueling and/or tuning.

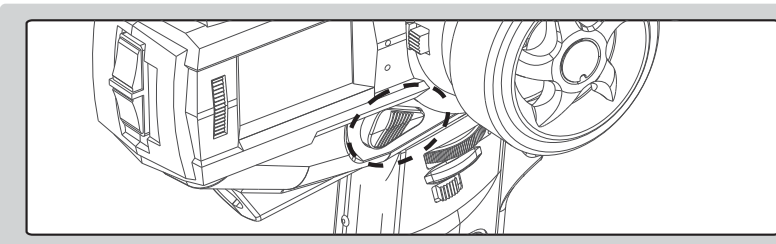

3. D/R (Dual Rate) Adjustment Dial

By using the dual rate adjustment dial, you can instantly increase or decrease your vehicle's overall steering travel rate.

When you want to increase the servo travel rate turn the dial forward, the rate can increase as high as 125%. When you want to decrease the servo travel rate, turn the dial backward; the rate can decrease as low as 60%. Use D/R (Dual Rate) control knob to stabilize model when it over-steers or under-steers during a corner-work

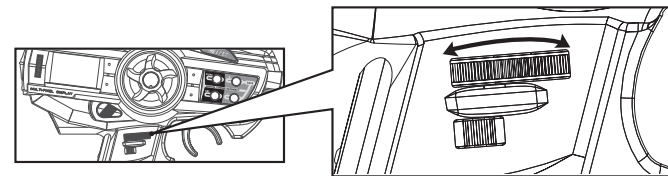
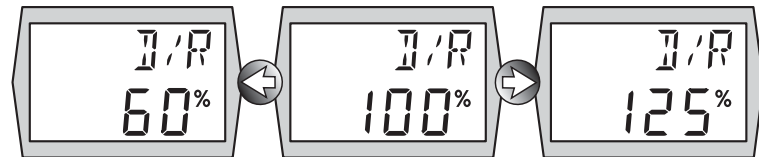

OVERSTEER

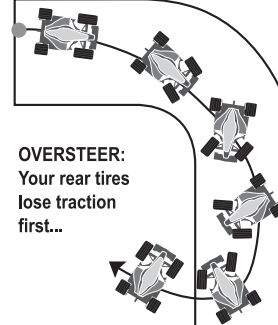

OVERSTEER:
Your rear tires
lose traction
first...

UNDERSTEER

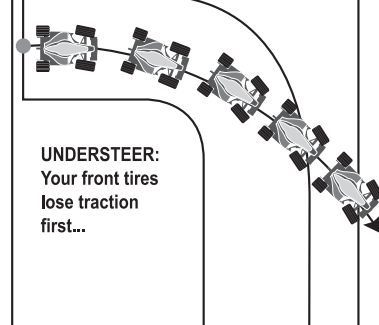

UNDERSTEER:
Your front tires
lose traction
first...

4. ATL Function

ATL(Adjustable Travel Limiter) function allows you to adjust the braking strength of your vehicle "on the drive." Increase this value for more braking and decrease the value for less.

NOTE: ATL function is sub function of Brake EPA setup function. Once End Point of Brake limit is set, ATL function can only increase or decrease the value within the EPA value.

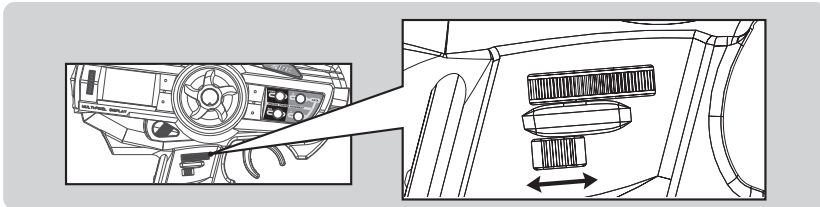

B. Main Menu

Entering the Main Menu

To enter the Main Edit Mode, you need to press and hold the "FUNC" button and turn the power switch on simultaneously.

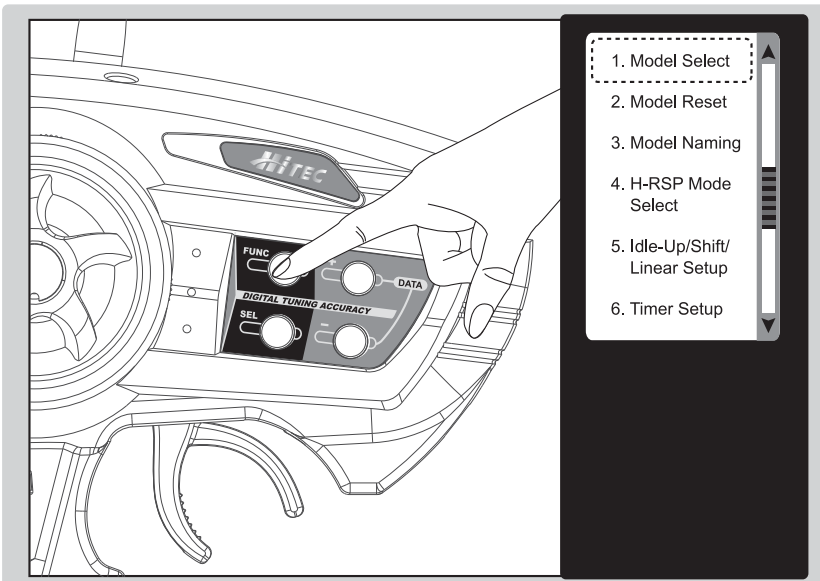

1. Model Select

You can choose ten different model memories from this menu

1. Press "FUNC" button to select "MDL"
2. Press "+" or "-" to select the model you want.
3. After the model is selected, press "FUNC" to scroll to the next menu, or turn the transmitter off and back on to use the radio.

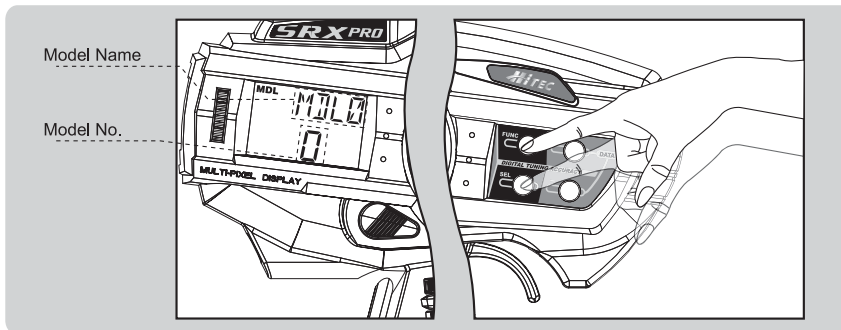

2. Model Reset

1. Press the "FUNC" button to scroll the menu until "REST" (Model Reset) menu appears.
2. To reset the model you choose press the DATA "+" and "-" buttons simultaneously to complete the reset process.
 * When properly done resetting, you will hear short two continuous beeping sounds
3. Press "FUNC" to scroll to the next menu, or turn the transmitter off and back on to use the radio.

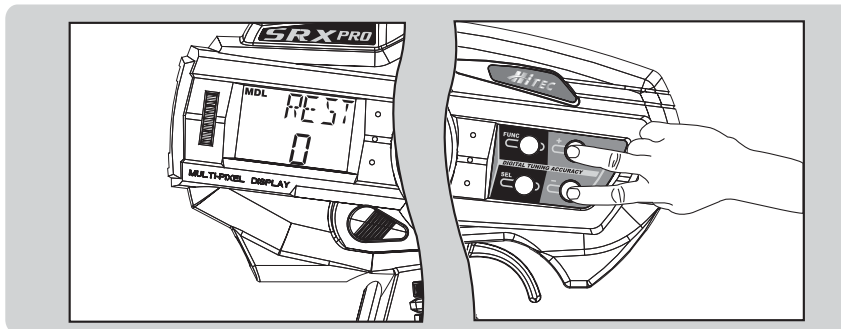

NOTE: After the reset process the customized settings will be deleted and the setup it will return to factory default.



3. Model Naming

You can name each model up to four characters.

1. Press the "FUNC" button to scroll the menu until "MDL" menu appears.
2. Press the "+" or "-" button to select the letter or symbol.
3. Press the "SEL" (Select) button to move the cursor to the next letter.
4. After the name is set, press the "FUNC" button to scroll to the next menu, or turn the transmitter off and back on to use the radio.

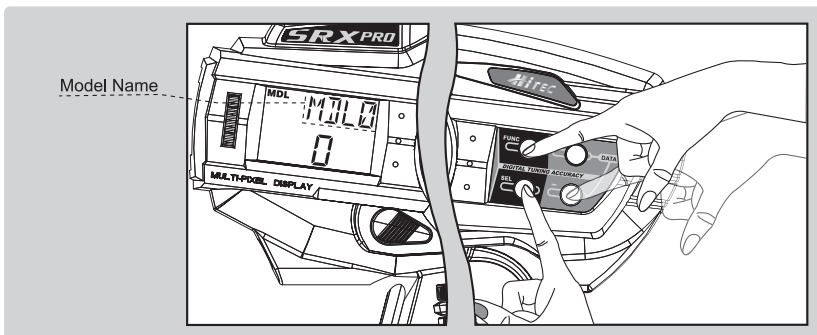

4. H-RSP (High-Response) Servo Control (Linear & Shift function disable):

Previous version Hitec Aggressor SRX has 14ms transmission latency.
 However, Hitec's upgraded Aggressor SRX-Pro shortens its latency down to 7ms for ultra fast and accurate response.

1. Press the "FUNC" button to scroll the menu until "H-RSP" appears on the screen.
2. Press the "+" or "-" button to turn the function on or off.
3. After the function is activated, press the "FUNC" button to scroll to the next menu, or turn the transmitter off and back on to use the radio.

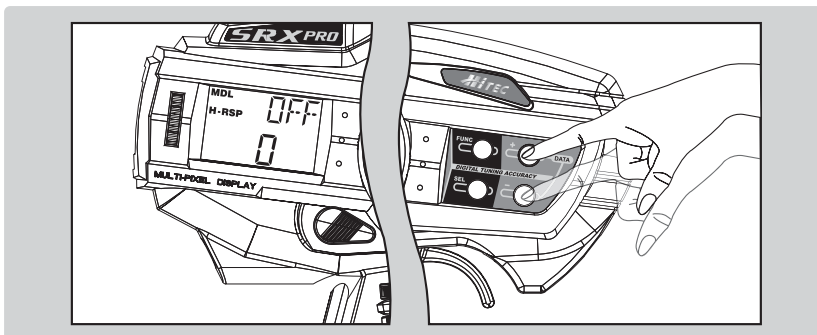

Note: H-RSP function cannot be used if you need the third channel.

*This function has been proven to work with Hitec and all other brand digital servos.
 Analog servos can't be used with this function.*



5. Third Channel Button:

Third channel button can be used for three different functions. You can use SHFT (shift), LINR (Linear), and IDLE (Idle-up) functions through this button.

Note: In order to use "Linear" or "Shift" function, H-RSP function must be turned off.

1. After entering the Main Edit mode press the "FUNC" button to scroll the menu until "LINR", "SHFT", or "IDLE" appear on the screen.
2. Push the "+" or "-" buttons to Select either "Linear", "Shift", "Idle-up".
3. Linear is activated via the trim tab on the right side of the steering column and can be moved to any position you select. This is typically used for fuel mixture control in nitro boats, but you can use it for other functions if needed.
4. Shift function can be activated by the 3rd Channel Button located on the left of the steering wheel. This function is used to shift the gear of a vehicles such as T-Maxx or similar type vehicles.
5. Press the "FUNC" button to scroll to the next menu, or turn the transmitter off and back on to use the radio.

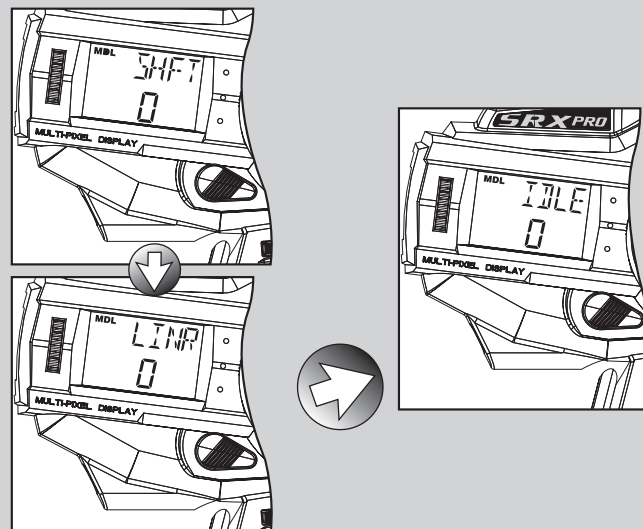

Tip: Use the left thumb to push the button to shift, When the button is pushed the AUX servo will travel to one end. When it is pushed again, it will travel to the other end.
This travel can be set in the EPA screen in the programming mode for fine tuning.



6. Timer

Timer function is very useful for you to estimate your vehicles run time.
It allows you to set a down timer from 01:00 up to 60:00 minutes.

How to setup:

1. From the Main Edit mode, use "FUNC" to scroll the "TIMER" mode.
2. Use "+" or "-" to adjust the time you wish to set.
3. Press the "FUNC" button to scroll to the next menu, or turn the transmitter off and back on to use the radio.
* factory default value is 10:00 minutes to reset to factory default setting press "+" and "-" simultaneously.

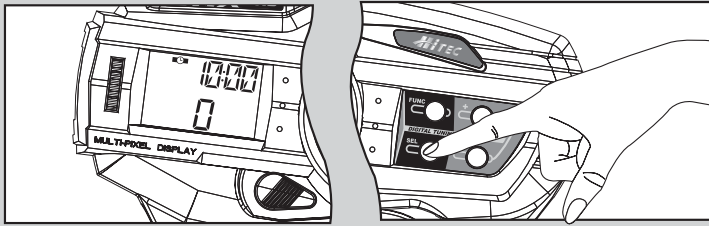

How to use:

- To activate the timer, push the "SEL" button.
- To pause and resume the timer, push the "SEL" button again.
- To cancel the timer, push the "FUNC" button.
- Note: You will hear beeps at every minute mark and when the timer reaches 00:10 seconds, it will beep for each second counting down until it reaches 00:00.

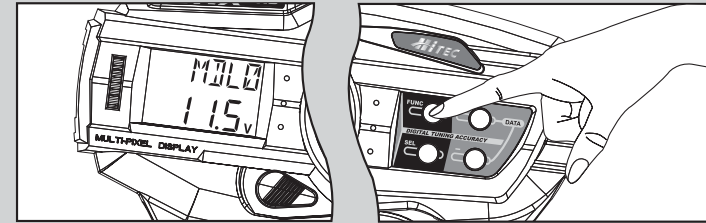
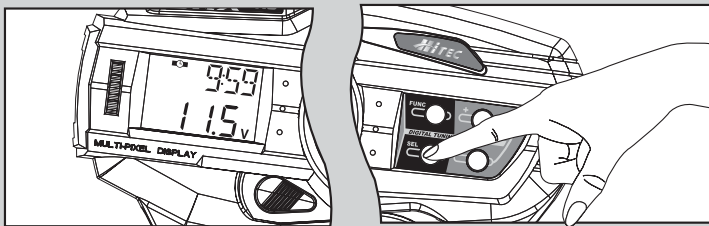

C. Programming Menu

The programming mode allows you to access the settings that you would typically change to set up your vehicle or change models.
The Programming mode screens will appear in the following order:

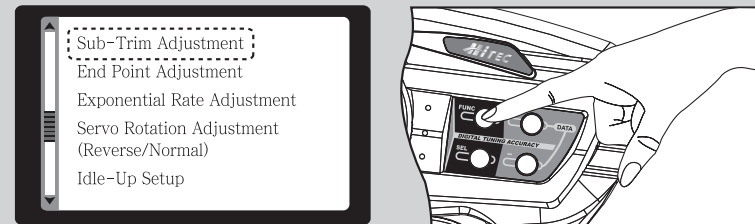

* You can Save & Exit from Programming Mode at any time by pressing "FUNC" button for 3 seconds.

Entering Programming Menu

1. Turn the power switch on
2. To access the menu, press "FUNC".
3. Use the "FUNC" button to scroll the menu.

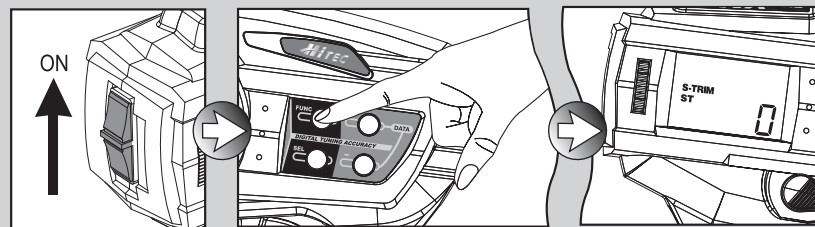

1. S-Trim (Sub-Trim)

What is Sub-Trim?

Sub-trim is a fine adjustment after mechanical setup of servo and its linkage. You need to set a servo in a proper center position with the linkage, and then use the Sub-trim function to make fine adjustment.

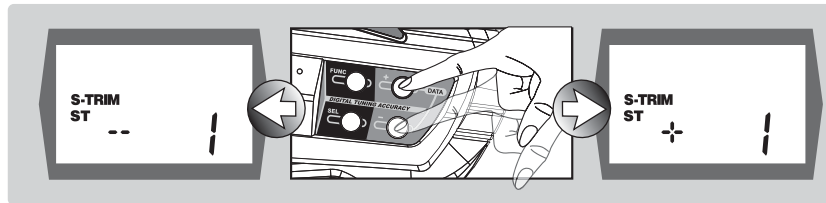
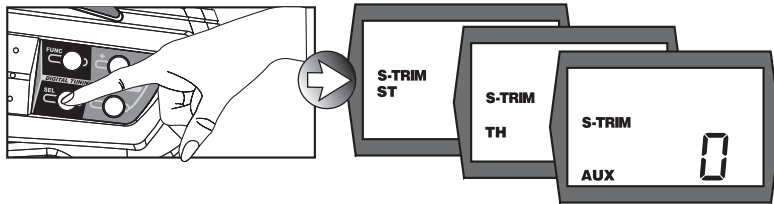

How to use it?

1. Press "FUNC" to enter the Programming mode.
2. Use the "FUNC" button to select "S-TRIM"
3. Use "SEL" button to choose "ST", "TH", or "AUX"
4. "ST", "TH", and "AUX" Stands for "Steering", "Throttle", and "AUXILIARY"
5. Press the "SEL" button to access the TH "throttle" sub-trim and adjust with the "DATA" + or - buttons to adjust the sub-trims forward or back.
6. Press the "SEL" button to access the AUX "Auxiliary" 3rd channel sub-trim and adjust with the "DATA" + or - buttons to adjust the sub-trims right or left.

Note: Push the DATA "+" & "-" buttons at the same time to reset to factory default.

7. Press the "FUNC" button to scroll to the next menu, or press the "FUNC" button for two seconds to return to the operation screen.
8. Press the "DATA" + or - buttons to Select the model to be used. (1-10)

Note: Be aware that if you wish to name or re-name a model, you will need to turn the radio off, and then follow the model naming instructions in the main edit mode.

9. Press the "FUNC" button to scroll to the next menu, or press the "FUNC" button for two seconds to return to the operation screen.

2. End Point Adjustment

EPA(End Point Adjustment) function allows you to adjust an each(left/right) travel end point of a servo.

In many cases, this function can be found useful when each end(Left/right or forward/brake) has different end position.

* This function can be adjusted between 0% to 125% in value.

ATL function can be used together with this function. (see page 19 for detailed information.)

- After entering the Programming mode press the "FUNC" button to scroll to the EPA menu.
- The current settings will show on this menu.

- STEERING EPA

- "Steering" will appear first. Use "+" button to adjust the EPA setting higher or "-" button to adjust it lower.

The factory setting is 100%. You can increase the end points up to 125% or down to 0%.

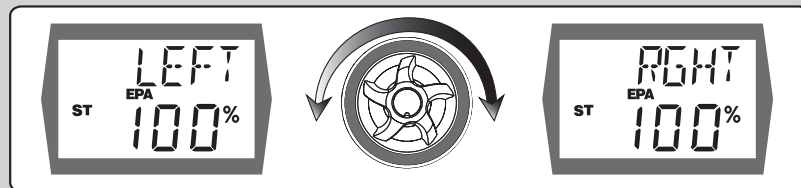

Note: You have to adjust left and right separately; you must turn the wheel in the direction you wish to set.

Tip: Always max out the dual rate dial to 125% before setting your individual end positions for maximum travel.

The best way to set the EPA is to turn and hold the steering wheel to the left end, then increase or decrease the EPA so the servo moves the car's wheels or the boat's rudder to their maximum travel without binding. Repeat for the right side.

- THROTTLE EPA

- Press the "SEL" button to get to the throttle EPA.

- To adjust the high throttle setting, pull and hold the trigger back.

- To adjust the Brake EPA push and hold the trigger forward.

- Note: The ATL switch on the handle under the D/R dial will adjust 0 to 100% of the Brake EPA setting.

- Tip: The ATL can be adjusted on the fly for fine tuning the braking power of the vehicle, and the current setting is displayed on the operating screen.

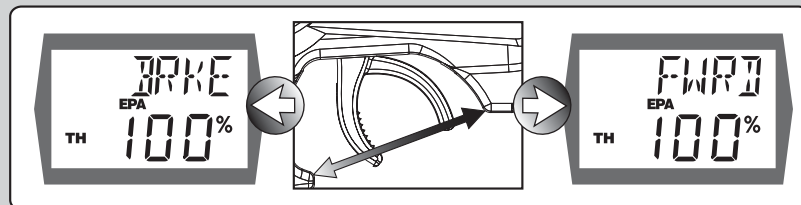

- AUXILIARY EPA "SHIFT"

- Press the "SEL" button to get to the "AUX" Auxiliary 3rd Channel EPA.
- If "SHIFT" was selected for this model, you will need to push the shift button to set each side of the travel.

**- AUXILIARY EPA "LINEAR"**

- Press the "SEL" button to get to the Auxiliary 3rd Channel EPA.
- Press the "SEL" button to loop back to the main EPA menu.
- Press the "FUNC" button to scroll to the next menu, or press the "FUNC" button for three seconds to return to the operation screen.
- AUXILIARY EPA "IDLE-UP"
- Press the "SEL" button to get to the "AUX" Auxiliary 3rd Channel EPA.
- If "IDLE" was selected for this model, you will need to push the shift button to set the rate of idle-up when the button pressed.



Note: If "LINEAR" was selected for this model, you will need to move the AUX digital trim tab on the right side of the steering column to the side you wish to set. Leaving the trim centered will adjust both sides at once.

The main EPA menu will now show all the new settings.

Push the "DATA" + & - buttons at the same time to reset to factory default.

3. Exponential Rate Adjustment

Negative steering exponential will make the vehicle less sensitive to small inputs and Positive exponential will make the vehicle more sensitive. Typically you will only use negative exponential for steering, but you should experiment with this setting to see what suits your driving style the best.

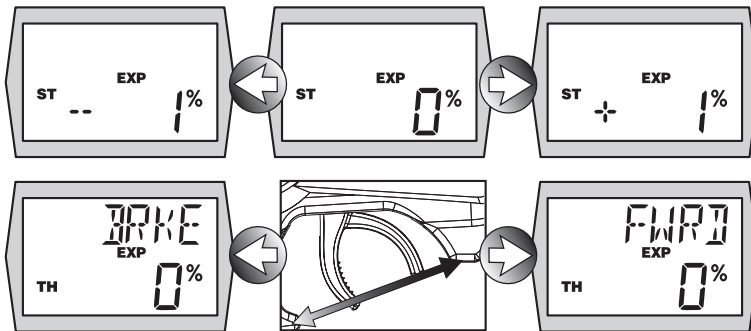

1. Press the "FUNC" button to scroll to the Exponential menu. "ST" (Steering) will show first, then "TH" (Throttle).
 2. Press the "+" button for positive Expo or the "-" button for negative expo.
 3. To adjust Throttle Exponential, press the "SEL" button once.
- * SRX-PRO can be set separated exponential rate setup for "FWRD"(forward) and "BRKE"(Brake).

4. To set FWRD and BRKE exponential rate, you need to either push or pull the trigger and then, Press the "+" button for positive Expo or the "-" button for negative expo.
5. Press "FUNC" to scroll to the next menu, or press the "FUNC" button for three seconds to return to the operation screen.

Note: Push the "+" & "-" buttons at the same time to reset to factory default.

-30% is a good place to start.

Use negative expo for the throttle to broaden the power band and positive expo to increase the "punch". Typically you will use negative expo with a modified electric vehicle, nitro vehicle, or in situation where the traction is low and positive with a stock electric or when the traction is high.

**4. Servo Reversing**

Use this function to switch the rotation of servo for variety installation location of a servo. Please note that, some other brand servos have different signal pulse than Hitec signal pulse.

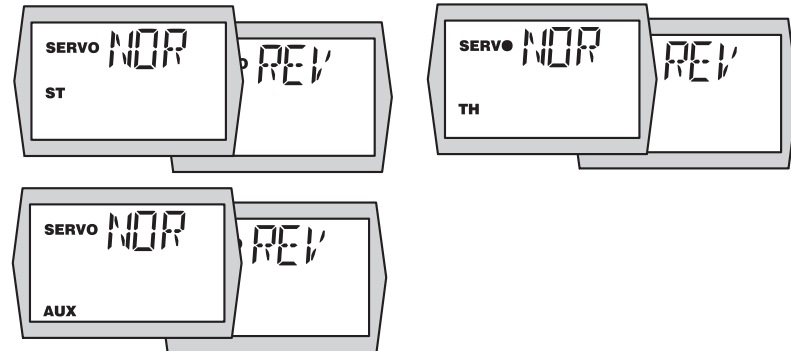
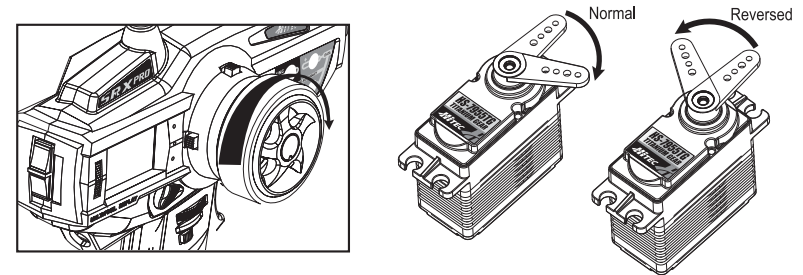

1. Press the "FUNC" button to scroll to "SERVO" menu.
2. Choose the servo you need to reverse, "ST" for Steering, "TH" for Throttle, and "AUX" for Auxiliary channel.
3. Once the proper channel is selected, press the "+" and "-" buttons simultaneously to reverse the servo rotation.
 - If properly done you will hear one "beep" and the display will change from "NOR" (Normal) to "REV" (Reverse) or vice versa.
 - Press the "FUNC" button to scroll to the next menu, or press the "FUNC" button for three seconds to return to the operation screen.

5. Idle-Up / Shift / Linear Function Setup

Idle-Up

This function allows you to increase the RPM at idle for start up, refueling and/or tuning. During this time Idle-Up function can be used to prevent unwanted engine stop or stall by fuel accumulation.

Simply press the 3rd channel button to increase the RPM at idling.

From Main Edit Menu select "IDLE UP" function and turn the feature on

1. Press "FUNC" to enter the programming mode
2. "FUNC" to scroll to the "IDLE" menu.
3. Press "SHIFT" once to "IDLE UP" on, and the indicator LED will start blink.
4. Use "+" and "-" button to adjust a throttle valve to open for higher RPM.
5. Press and hold "FUNC" button to save the setting and exit the mode.
6. Use the "SHIFT" button to confirm the idle up function works properly.

WARNING : After the IDLE UP setting, extra caution is required for the first time use. If the RPM setup is too high, your vehicle may accidently runaway.



NOTE: In H-RSP mode you cannot use SHIFT, or LINEAR function not works.



Shift

For many Nitro & Gas powered monster trucks, rock crawler, and scale vehicles equipped with forward/reverse gearbox units. Using this function can shift gear into either forward or reverse position by using 3rd channel switch.

Linear

For a tank's turret control or boat's fuel mixture adjustment this linear function can be found useful. Using D-Trim switch of the radio, you could adjust a servo's position.

Note: When Idle-up function activated only Shift function work together.



V. Warnings

- Never operate your car or truck in a crowded street with traffic.
- Always extend your transmitter antenna when in operation.
- Always check the battery power indicator before use.
- Do not operate two or more models on the same frequency at the same time.
- Do not operate your model in the rain or run through standing water.
- Do not operate your model within one mile of a radio control racetrack.
- Do not operate your model while under the influence of drugs or alcohol.
- Always turn on your transmitter first and then the receiver to prevent loss of control.
- When collapsing your antenna, never push it from the top or it may bend.

VI. Troubleshooting Guide

Question: I installed the batteries in my transmitter, but the power lights do not come on:

Answer:

- Check that the batteries are properly installed by checking the polarity (+ and -).
- Question: My radio has power, but I have no control:

Answers:

- Check to be sure the power switch is on and connected to the receiver.
- Make sure the batteries are charged (Replace or recharge if needed.)
- Make sure you are using the proper crystals.

Answers:

- Check that there are no radios operating on your channel.
- Make sure your electric motor has capacitors and the comutator is clean and brushes are not worn out. Replace if needed.
- Check for loose screws as metal-to-metal contact can cause interference.
- Make sure your receiver antenna has not been damaged or cut.
- Make sure the power wires are at least 2" away from the receiver.
- Replace the crystals if needed.
- If all fails, send the system in to be serviced, as there may be internal damage.

H-RSP & Function Availability Comparison Chart				
	FUNCTION	STEERING	THROTTLE	AUX(3rd. Ch)*
SHFT	Sub-trim	●	●	
	EPA	●	●	●
	EXP	●	●	
	SERVO	●	●	●
LINR	Sub-trim	●	●	●
	EPA	●	●	●
	EXP	●	●	
	SERVO	●	●	●
IDLE UP	Sub-trim	●	●	
	EPA	●	●	●
	EXP	●	●	
	SERVO	●	●	●
	IDLE	Customize the Idle-up Value		

* For the fast response of H-RSP, most of third channel functions will be disabled while H-RSP mode is activated. Only Idle-Up function can be used.